



Return Path Level Selection, Setup, and Alignment Procedure

Reference Guide

453760-001 Revision B

Return Path Level Selection, Setup, and Alignment Procedure

Reference Guide

453760-001 Revision B



Return Path Level Selection, Setup, and Alignment Procedure Reference Guide

Document Number: 453760-001 Revision B

Copyright © 2005, 2008, 2012, 2014 ARRIS Group, Inc. All rights reserved.

Trademarks

©ARRIS Enterprises, Inc. 2014 All rights reserved. No part of this publication may be reproduced in any form or by any means or used to make any derivative work (such as translation, transformation, or adaptation) without written permission from ARRIS Enterprises, Inc. ("ARRIS"). ARRIS reserves the right to revise this publication and to make changes in content from time to time without obligation on the part of ARRIS to provide notification of such revision or change.

ARRIS and the ARRIS logo are all trademarks of ARRIS Enterprises, Inc. Other trademarks and trade names may be used in this document to refer to either the entities claiming the marks and the names of their products. ARRIS disclaims proprietary interest in the marks and names of others.

ARRIS provides this guide without warranty of any kind, implied or expressed, including, but not limited to, the implied warranties of merchantability and fitness for a particular purpose. ARRIS may make improvements or changes in the product(s) described in this manual at any time.

The capabilities, system requirements and/or compatibility with third-party products described herein are subject to change without notice.

Revision History

Revision	Date	Reason for Change
A	6/1998	Initial release.
B	9/2014	Rebranded to conform with current corporate style guidelines. Revised extensively to bring information up to date.

Contacting ARRIS

Help with your ARRIS product is available online and by phone:

Customer Care

- Contact us via the ARRIS CUSTOMERCARE 360 website (www.arris.com/customercare360) to report non-critical Severity 4 issues. We will answer your service request within one business day. You can also use the Customer Care portal to update and close your support requests and add attachments, if required, to your open tickets.
- Find technical documentation at www.arris.com/accesstechnologies

Technical Support

Contact Technical Support when you need assistance with installed products.

The ARRIS TAC Call Center provides Customer support 24/7/365. A TAC agent will create your case and escalate to the appropriate technical support team. Critical Severity 1 or 2 issues will be warm transferred for immediate assistance.

North America

Phone: 1-888-944-HELP (4357); + 1-215-323-2345 (worldwide)

Email: TAC.Helpdesk@arris.com

Contact TAC via email to report non-critical Severity 3 or 4 issues. Contact the TAC by phone at 1-888-944-4357 for Critical Severity 1 or 2 issues.

Latin America

Phone: +1-215-323-2346

Email: TAC.Helpdesk@arris.com

Europe

Phone: +1-215-323-2345

Email: TAC.Helpdesk@arris.com

Japan/Korea/Asia

Phone: No in region numbers

Email: TAC.Helpdesk@arris.com

Technical Training

Contact Technical Training for inquiries at 1-888-221-9797 concerning product training. Please be prepared to provide a list of equipment you would like training on.

Email: training@arris.com

Repair Services

Contact Repair Services if you need to return a product for repair. Please go to the ARRIS website (<http://www.arris.com>), click the **Support** link, and then click the **Repair Services** link for more information.

Table of Contents

Chapter 1	Introduction	1-1
	Using This Document	1-1
	Related Documentation	1-2
	Document Conventions	1-2
Chapter 2	Overview	2-1
	Choosing Operating Levels	2-1
	Long-Loop AGC	2-2
	Headend Combining and Splitting	2-2
	Levels in the Optical Link — Constant Power per Hz	2-2
	Levels in the RF Plant	2-4
	Choosing the Best Plant Level	2-7
	Node Return Gain	2-11
	Carrier to Noise Ratio and Distortion	2-12
	Summary	2-12
	Unity Gain	2-13
	Pads and Equalizers	2-14
	Location	2-14
Chapter 3	Alignment	3-1
	Strategy	3-1
	Signal Levels Versus Gains and Losses	3-2
	Insertion Point	3-3
	Compensating for Insertion Point Loss	3-4
	Optical Link Alignment	3-5
	Unity Gain Between Optical Links	3-5
	Optical Link Level and Gain Tables	3-5
	Alignment Procedure	3-7
	Reference Level Calculations	3-7
	Optical Link Alignment	3-8
	Setting the Node Return Gain	3-10
	Combined Node Return Gain and Optical Link Alignment	3-12
	RF Plant Alignment	3-14
Appendix A	Other Conditions	A-1
	Changes in Forward Levels	A-1
	Using Trunk Amplifiers	A-2
	Using Express Feeders	A-3
Appendix B	Station Block Diagrams	B-1
Appendix C	Design Table	C-1
Appendix D	Glossary	D-1

INTRODUCTION

The return path of the cable television plant has received very little attention over the years. Although many procedures for aligning and troubleshooting the forward path have been written, very few exist for the return path. In addition, the return path poses some unique challenges that make the alignment of the plant somewhat more difficult.

This guide explains how the return path should be aligned. A great amount of detail is placed on the decisions that must be made about the plant before any alignment can begin. These decisions include the choice of laser operating point, the selection of plant operating levels, the method of combining signals in the headend, how to choose the proper unity gain point, and many other topics. These details are an important prerequisite to aligning the return path and are discussed before the actual alignment procedures to be used by the technician.

Using This Document

The following sections provide information and instructions that enable you to determine correct plant operating levels and alignment procedures for the return path:

Section 1	Introduction provides a description of the content, conventions used, and other information relevant to this document.
Section 2	Overview describes the tasks required and presents alternatives for designing the return path.
Section 3	Alignment provides a description of the strategy used and specific instructions on how to implement the procedures required for proper return path plant levels.
Appendix A	Other Conditions presents various nonstandard conditions that require unique approaches to proper return plant alignment.
Appendix B	Station Block Diagrams presents diagrams of the amplifiers and nodes most commonly used in forward and return path transmission.
Appendix C	Design Table provides a blank, working template that is useful for plant design and choosing the proper plant level.
Appendix D	The Glossary provides a list of the abbreviations and acronyms and definitions of the special terms used in this guide.

Related Documentation

Although these additional documents provide information that may be of interest to you, they are not required to perform setup of plant return-path levels:

- Designing the Return System for Full Digital Services, Stoneback, D. and Beck, W.; SCTE Conference on Emerging Technologies. San Francisco, CA: January 1996.
- Broadband Return Systems for Hybrid Fiber/Coax Cable TV Networks, Raskin, D. and Stoneback, D; Prentice-Hall PTR, 1998, ISBN 0-13-636515-9.

Document Conventions

Before you begin using this reference guide, familiarize yourself with the stylistic conventions used in this guide:

SMALL CAPS	Denotes silk screening on the equipment, typically representing front- and rear-panel controls, input/output (I/O) connections, and indicators (LEDs)
* (asterisk)	Indicates that several versions of the same model number exist and the information applies to all models; when the information applies to a specific model, the complete model number is given
<i>Italic type</i>	Used to emphasize statements and facts. It is also used when referring to published documents that support this reference guide.

OVERVIEW

The setup and alignment procedures for the return-path are very similar to those for the forward-path in some respects and very different in others. While this document provides detailed discussion of the similarities and differences of the return and forward paths, they are summarized below for convenience.

Similarities:

- Both are aligned for unity gain
- Alignment procedures start at the node and move outward

Differences:

- The forward path has constant signal presence enabling measurement at any location
- The return path requires the injection of a signal at a specific location

The easiest way to align both the forward and return paths is to start at the center (node) and move outward. In this respect, the node can be compared to a tree-and-branch architecture as signals continue to branch-off as the distance from the optical node increases. To align the return path, a signal must be generated locally and monitored at the headend.

The method used for return path alignment is the “round-robin” method which enables alignment of all equipment between the current location and the headend. The method involves placing a piece of receiving equipment at the headend that monitors the signals received from the return plant and sends that information back out into the plant through the forward path. Several methods can be used to accomplish this task and are discussed later. The “round-robin” sweep requires inserting a signal into the return path at a specific location. The level(s) received at the headend are then sent back to this location through the forward path. As a result, signal activity in the return path between the technician's present location and the headend is visible.

Choosing Operating Levels

Proper alignment of the return path cannot be accomplished until the operating levels are chosen. This is because the system consists of two distinctly different portions: the RF plant and the optical link. Both portions need to be operated at the correct signal level, although these levels are chosen in very different manners. Once the levels for both portions are chosen, you will know how much gain or loss is required inside the optical node, which is

where the RF plant feeds the optical link. Because return path alignment begins at the optical node, no progress can be made before this relationship between RF plant and optical link levels is determined.

Having two independent operating levels is not unique to the return path as these two types of operating levels also exist in the forward path. One set of operating levels applies to the optical link and the other to the RF plant operating levels. The two levels are not related in any direct manner. The level out of the optical link depends on link loss and transmitter characteristics. The level in the RF plant is chosen by other design criteria and is independent of link loss or node location. A specific gain is required in each node to transition from optical link levels to RF plant levels.

Long-Loop AGC

Before diving into the actual levels in the optical link and RF plant, the long-loop automatic gain control (AGC) needs to be understood. The long-loop AGC refers to the gain control that should occur within every service that operates on the return path. Each service in the plant is supposed to operate at a predetermined level. The long loop AGC is the mechanism through which the levels are adjusted. Because the amount of loss between the subscriber's equipment and the cable plant (in-house cable, in-house splitters, drop loss, feeder loss, and other losses) is not known, there is no way to predict what transmitter level is required to ensure that the return path signal enters the plant at the correct level. The receiver in the headend examines the level received from a particular transmitter and determines whether the level is correct, too high, or too low. If the level is incorrect, the receiver issues a command to the transmitter (through the forward path) to change its level. Because this AGC loop operates outside any plant gain control loops, it is referred to as the "long-loop" AGC.

Any service that does not have long-loop AGC will not function properly in the return path. The noncontrolled service itself may function properly, but if its levels are too high it can cause distortion that corrupts other services in the return path.

Headend Combining and Splitting

This document deals primarily with the setup and alignment of the cable system between the tap port in the plant and the fiberoptic receiver in the headend. The combining loss in the headend is a very complex subject that is worthy of its own document and therefore is not discussed here. When a signal arrives at the headend (at the output of the fiberoptic receiver), it is distributed to the various application receivers (demodulators). The amount of loss between the fiberoptic receiver and the application receiver is critical. As noted in the long-loop AGC discussion, the application receiver issues commands to the transmitters, causing them to adjust their output levels. The application receiver's response is based on the level it receives. This level however may, or may not, bear any resemblance to the actual fiber link and plant levels. The headend design must ensure that when the application receiver thinks the level is correct, the level is in fact correct in the plant.

Levels in the Optical Link — Constant Power per Hz

The levels in the optical link are primarily dictated by the drive capability of the laser. The laser manufacturer provides the value for the recommended total composite power applied to the return laser transmitter module. This recommended value should be high enough to provide adequate c/n and low enough to provide sufficient headroom for large interference and ingress. These levels are optimized for the best compromise between noise and distortion for heavy digital data traffic. Table 2.1 lists the levels for most ARRIS transmitters.

Table 2.1 Transmitter input levels

Model	Recommended Total Input Power for Full Data Loading (dBmV)
AM-RPTD	20
AM-RPTV1	25
AM-RPTV4	25
AM-MB-RPTD	40
AM-BTN-RPTV1	45
AM-TC-RPT	45
SG2-DFBT	15
SG2-IFPT	15
AM-OMNI-RPT	15

Once the desired level into the transmitter is known, the preferred level for each service using the return path must be chosen. The easiest way to do this is to assign the available power to each service on the basis of constant power per Hz. For a complete explanation of assigning power refer to Designing the Return System for Full Digital Services or Broadband Return Systems for Hybrid Fiber/Coax Cable TV Networks.

The method of assigning power on the basis of constant power per Hz is to first divide the total available power into 1 Hz increments. The choice of 1 Hz is convenient because many spectrum analyzers have a feature that makes measurements in a 1 Hz bandwidth. Before you begin, the total bandwidth of the system to be occupied by services must be known. This total bandwidth should not include regions of the spectrum that are not used, such as the CB band if ingress is bad, or pieces of the spectrum that are reserved for frequency hopping. The allotted power per Hz is then assigned to each channel based on the bandwidth occupied by the channel. The equations are summarized as:

$$\text{Power per Hz} = \frac{\text{Total power}}{\text{Total bandwidth}}$$

In log terms this is:

$$\text{Power per Hz} = \text{total power} - 10 \cdot \log(\text{total bandwidth})$$

Example — Input power for the AM-TC-RPT is:

$$\text{Power per Hz} = 45 \text{ dBmV} - 10 \cdot \log(35 \text{ MHz})$$

$$\text{Power per Hz} = -30 \text{ dBmV/Hz}$$

To calculate the amount of power that can be allocated to a given channel, the bandwidth of the channel must be known. In the above example, the power for a 200 kHz channel is:

$$\text{Channel power} = \text{power per Hz} + 10 \cdot \log(\text{channel bandwidth})$$

$$\text{Channel power} = -30 \text{ dBmV/Hz} + 10 \cdot \log(200 \text{ kHz})$$

$$\text{Channel power} = 23 \text{ dBmV}$$

The power allocated to the channel should be calculated from the channel's spacing rather than from its noise bandwidth. For example, a particular service has a 128 kHz noise bandwidth; but in a fully loaded system, these channels could be centered 200 kHz apart. If the power for the channel is allocated based on 128 kHz, some of the power available at the laser will not be allocated. In other words, any guard bands should be allocated as part of the channel. Multitone communications schemes such as orthogonal frequency division multiplexing (OFDM) could be calculated in the same manner. The entire power available to the channels that occupy any given bandwidth should be calculated based on the total bandwidth allocated to the channels.

Table 2.2 shows a fully loaded return path spectrum. When all services are running simultaneously at 100% capacity, the total power is equal to the laser transmitter's recommended total input power. As noted earlier, General Instrument's recommended total input power is optimized for the best compromise between noise and distortion and includes headroom for ingress and large interference.

Table 2.2 Power allocation example

Type of Signal	Channel Spacing (BW)	Power per Channel (dBmV)	Number of Channels	Total BW (MHz)	Total Power (dBmV)
Interactive services	192 kHz	23	36	7	38
Telephony	2 MHz	33	10	20	43
Other services	1 MHz	30	8	8	39
Total	35	45			

Notes:

Total power to transmitter = 45 dBmV
 Total payload BW = 35 MHz
 Power per Hz = -30 dBmV/Hz
Calculate the total value, in the total power column, using logarithmic power addition.

Levels in the RF Plant

The levels in the RF plant are primarily dictated by the plant design and by the type and location of the terminal equipment that transmits into the return path. As in the optical link design, the levels of the various services in the plant are allocated on the basis of constant-power-per-Hz. The goal is to keep the plant levels as high as possible to get the signals far above ingress. Choosing the proper plant operating levels requires that you first find out what level can be delivered to an amplifier station's return path input. This should be determined when the terminal equipment's return path transmitter is transmitting at full power and the signal is traveling through the maximum permissible loss. To do this, you must obtain two pieces of information: (1) the maximum permissible loss between the transmitter and the amplifier and (2) the maximum guaranteed transmitter output level.

Loss Between the Transmitter and Amplifier

Maximum loss is determined by plant design, gain changes in the return path, and other variables as discussed below.

Loss of Feeder Cable and Taps

To understand the levels in an RF plant, the design of the plant must be examined. Figure 2.1 illustrates a typical feeder system with the choice of tap values based on the forward path signal levels:

Figure 2.1

Tapped feeder

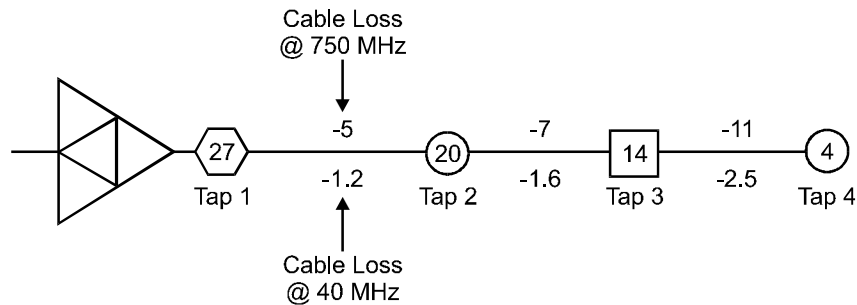

Table 2.3 shows the resulting loss of the feeder cable and taps between the amplifier and the tap port for both the forward and return paths:

Table 2.3 Loss of feeder cable and taps

Tap Number	Loss of Feeder Cable and Taps @ 750 MHz	Loss of Feeder Cable and Taps @ 40 MHz
1	27 dB	27 dB
2	25 dB	21.2 dB
3	26 dB	16.8 dB
4	27 dB	9.3 dB
Difference between tap 4 and tap 1	0 dB	17.7 dB

Table 2.3 represents a section of the feeder system indicating a minimum loss of 9.3 dB and a maximum loss of 27 dB from the tap port to the amplifier. Although rarely used, 29 dB taps can still be encountered and contribute additional loss.

In the return path, various amounts of loss can occur between the amplifier and a subscriber's tap. To correct for this range of loss, the transmitters in the home must have variable outputs so that their signals can reach the amplifier at the correct level. This wide range of loss also enables extra ingress through the taps that have the least amount of loss between the tap port and the amplifier. Refer to *Designing the Return System for Full Digital Services*, for additional information.

The major concern when choosing proper plant levels is the maximum loss between the home and the nearest amplifier. The goal is to determine what level can be obtained at the amplifier's return path input when the transmitter is sending its signal through this maximum loss. As indicated in Table 2.3, the maximum loss is 27 dB.

Adding Up the Losses

The amount of loss between the tap port and the terminal equipment must be determined. This loss consists mainly of drop-cable loss, in-house splitting, and cable loss. The amount of in-house loss depends on the type of services deployed and their physical location in the house. For example, services such as cable modems can be fed through directional couplers, while other services such as set-top terminals can be fed through a four-way splitter. Table 2.4 shows how all losses can be added together to obtain the maximum total loss:

Table 2.4 Losses from terminal equipment to amplifier

Device	Minimum Loss	Typical Loss	Maximum Loss
Feeder cable and taps	9	20	27
Drop-cable loss	1	2	3
In-house loss	0	4	9
Total loss	10	26	39

Plant Gain Errors

Loss between a particular amplifier and the terminal equipment was discussed above. Loss between various amplifiers must be considered as well. Because the plant is aligned to unity gain, the expected loss is 0 dB. However, no alignment is perfect, and some error will occur. Plant unity gain accuracy and drift with temperature change are two design and operational issues that affect the maximum loss between the terminal equipment and the amplifier. Sources of plant gain error, and sample values, are listed in Table 2.5:

Table 2.5 Plant gain error

Device	Drift Down	Drift Up
Optical link alignment accuracy	-1	+1
Unity gain alignment accuracy	-1	+1
Changes due to temperature	-4	+4
Total	-6	+6

Transmitter Level and Bandwidth

With all losses known, one of the last steps in determining the proper plant level is to ascertain the guaranteed maximum output level of the transmitter. While many set-top terminals transmit at a nominal +60 dBmV, the guaranteed output level must be determined for correct plant operation. Once this guaranteed channel power is known, the power-per-Hz can be calculated. Remember, the goal is to allocate the power on a constant-power-per-Hz basis on a return path that consists of many different services all having different bandwidths.

To calculate the power-per-Hz from the channel power, use the following formula.

Calculating Power per Hz from Channel Power:

$$\text{Power-per-Hz} = \text{channel power} - 10 \cdot \log(\text{channel bandwidth})$$

Example: A set-top terminal has a guaranteed maximum output level of +58 dBmV and a channel bandwidth of 200 kHz. The power-per-Hz is:

$$\text{Power-per-Hz} = 58 \text{ dBmV} - 10 \cdot \log(200 \text{ kHz}) = 5 \text{ dBmV/Hz}$$



Note Use the occupied bandwidth or channel spacing, not the receiver's noise bandwidth.

Choosing the Best Plant Level

The best plant level is determined by subtracting the total loss between the transmitter and the amplifier from the transmitter's output level. This must be done for every service that is operated on the return path. The service that provides the lowest level to the amplifier is the service that dictates the maximum plant level. All other services can get to that level by lowering their output.

Table 2.6 presents a method that can be used to determine the plant level at the amplifier input.

The services listed as Service 1 and Service 2, and the calculations used for those services, are presented as examples only.

Table 2.6 Choosing the proper plant level

Step	Description	Procedure	Service 1	Service 2
1	Name of service	Enter the name of the service.	Set-top	Cable modem
2	Bandwidth	Enter the bandwidth of the service listed in Step 1. This is usually the same as the channel spacing.	200 kHz	1 MHz
3	Guaranteed maximum level (dBmV)	Enter the guaranteed maximum output level of the service listed in Step 1.	+58	+56
4	Plant gain errors (dB)	Enter the anticipated maximum plant gain errors. Refer to Plant Gain Errors above.	6	6

Table 2.6 Choosing the proper plant level (cont'd)

5	In-house loss (dB)	Enter the maximum in-house loss for the service listed in Step 1. Refer to Adding up the Losses above.	9	9
6	Drop loss (dB)	Enter the maximum drop-cable loss. Refer to Adding up the Losses.	3	3
7	Level at tap port (dBmV)	Determined by subtracting Steps 4, 5, and 6 from Step 3	40	38
8	Loss of feeder cable and taps (dB)	Enter the maximum loss of the feeder cable and taps. Refer to Loss of Feeder Cable and Taps above.	27	27
Level/Power at Amplifier Input				
9	Level at amplifier input (dBmV)	Determined by subtracting Step 8 from Step 7.	13	11
10	Power per Hz at amplifier input (dBmV/Hz)	Calculate from the bandwidth in Step 2 and the level in Step 9 by using the Calculating Power per Hz from Channel Power conversion formula above.	-40	-49
11	Total power at amplifier input (dBmV)	Calculate using the formula Calculating Total Power from Power per Hz below. This is the total power at the amplifier input port if the service given in Step 1 is used as the basis for choosing the plant operating level.	35	26

Table 2.6 can be used to find the best plant level. It is also useful for helping the system designer visualize the tradeoffs between transmitter level and bandwidth and the various losses between the transmitter and the amplifier. Steps 9, 10, and 11 all give the level of a particular service at the amplifier input. Step 9 gives the level of the service in dBmV. Step 10 gives the level of the service in dBmV/Hz. Step 11 gives the total power at the amplifier input if all services were transmitted at the power per Hz given in Step 10. Either Step 10 or Step 11 can be used to make design tradeoffs depending on personal preference.

For convenience in designing your system, a blank version of Table 2.6 is provided in Appendix C, *Design Table*.

To calculate total power from power per Hz use the following formula.

Calculating Total Power from Power per Hz:

$$\text{Total Power} = \text{Power per Hz} + 10 \cdot \log(\text{total bandwidth})$$

As an example for Service 1 in Table 2.6, the calculation is:

$$\text{Total Power} = -40 \text{ dBmV/Hz} + 10 \cdot \log(35 \text{ MHz}) = 35 \text{ dBmV}$$

As an example for Service 2 in Table 2.6, the calculation is:

$$\text{Total Power} = -49 \text{ dBmV/Hz} + 10 \cdot \log(35 \text{ MHz}) = 26 \text{ dBmV}$$

The goal is to obtain the highest possible level at the amplifier input. Table 2.6 shows that the highest possible level is dictated by Service 2 (cable modem). The modem delivers only -49 dBmV/Hz to the amplifier, while Service 1 (set-top) delivers -40 dBmV/Hz. Design tradeoffs are now considered. If the modem level is used as the design criteria, 9 dB of the set-top's output range is never used and the plant operates 9 dB closer to ingress. If the set-top is used as the design criteria, some of the modems may not work. At this point, the system designer must determine the proper tradeoff between these conflicting goals. A common approach is to choose a level somewhere in the middle. It is reasonable to assume that very few modems are actually on the highest value tap, exposed to the worst temperature, operating with maximum in-house splitting loss, and connected to a long drop all at the same time.

A possible compromise is presented in Table 2.7. Losses for the set-top are increased and the losses for the cable modem are decreased such that both services arrive at the amplifier at the same power per Hz. Changed parameters are indicated in bold print with the original values in parentheses.

Table 2.7 Choosing the proper plant level — lowering the loss to the modem

Step	Description	Service 1	Service 2
1	Name of service.	Set-top	Cable modem
2	Bandwidth.	200 kHz	1 MHz
3	Guaranteed maximum level (dBmV)..	+58	+56
4	Plant gain errors (dB).	6 (6)	6 (6)
5	In-house loss (dB).	12 (9)	6 (9)
6	Drop-cable loss (dB).	3 (3)	3 (3)
7	Level at tap port (dBmV). Determined by subtracting Steps 4, 5, and 6 from Step 3.	37 (40)	41 (38)
8	Loss of feeder cable and taps (dB).	27 (27)	24 (27)
Level/Power at Amplifier Input			
9	Level at amplifier input (dBmV). Determined by subtracting Step 8 from Step 7.	10 (13)	17 (11)
10	Power per Hz at amplifier input (dBmV/Hz).	-43 (-40)	-43 (-49)
11	Total power at amplifier input (dBmV).	32 (35)	32 (26)

An alternative compromise is to assign a larger bandwidth to the set-top terminal. For example, a 200 kHz set-top terminal can be allocated 1.6 MHz of spectrum, as shown in Table 2.8. The set-top terminal uses only 200 kHz, but no other signals can occupy the rest of the 1.6 MHz spectrum because the power is already allocated. In some systems where very few set-top terminal frequencies are required, this is an advantageous compromise.

Table 2.8 Choosing the proper plant level — assigning larger bandwidth to set-top terminals

Step	Description	Service 1	Service 2
1	Name of service.	Set-top	Cable modem
2	Bandwidth.	1.6 MHz	1 MHz
3	Guaranteed maximum level (dBmV).	+58	+56
4	Plant gain errors (dB).	6 (6)	6 (6)
5	In-house loss (dB).	9 (9)	9 (9)
6	Drop-cable loss (dB).	3 (3)	3 (3)
7	Level at tap port (dBmV). Determined by subtracting Steps 4, 5, and 6 from Step 3.	40 (40)	38 (38)
8	Loss of feeder cable and taps (dB).	27 (27)	27 (27)
Level/Power at Amplifier Input			
9	Level at amplifier input (dBmV). Determined by subtracting Step 8 from Step 7	13 (13)	11 (11)
10	Power per Hz at amplifier input (dBmV/Hz).	-49 (-40)	-49 (-49)
11	Total power at amplifier input (dBmV).	26 (35)	26 (26)

The best plant levels may result from a combination of the previous two compromises. Such a combination is presented in Table 2.9 and is used for the rest of this procedure:

Table 2.9 Choosing the proper plant level — combination

Step	Description	Service 1	Service 2
1	Name of service	Set-top	Cable modem
2	Bandwidth	1 MHz	1 MHz
3	Guaranteed maximum level (dBmV)	+58	+56
4	Plant gain errors (dB)	6 (6)	6 (6)
5	In-house loss (dB)	9 (9)	7 (9)
6	Drop-cable loss (dB)	3 (3)	3 (3)
7	Level at tap port (dBmV). Determined by subtracting Steps 4, 5, and 6 from Step 3.	40 (40)	40 (38)
8	Loss of feeder cable and taps (dB)	27 (27)	27 (27)
Level/Power at Amplifier Input			
9	Level at amplifier input (dBmV). Determined by subtracting Step 8 from Step 7.	13 (13)	13 (11)

Table 2.9 Choosing the proper plant level — combination (cont'd)

10	Power per Hz at amplifier input (dBmV/Hz)	-47 (-40)	-47 (-49)
11	Total power at amplifier input (dBmV)	28 (35)	28 (26)

There is an alternative solution to the problem of having a service with an inadequate transmitter level. Instead of lowering the levels of all services, the level required of the weak service can be lowered while the level required from the rest of the services remains high. One problem with this option is that when the signals all get to the optical link, the service with the lower level is operating at a lower c/n than the rest of the services on the fiber. Another problem is that the levels are harder to troubleshoot when the plant is operational. The major advantage to this option is that the rest of the services are not taken closer to the ingress level.

In summary, the highest transmitter level is required from the service with the highest in-house loss and widest bandwidth.

The methods of choosing proper plant levels described in this section are provided for the purpose of illustration only. Examples presented in the remainder of this document use the total power value of 28 dBmV, as given in Table 2.9.

Node Return Gain

Knowledge of the plant levels and the laser levels enables you to determine the required internal return path gain of the node station. Figure 2.2 illustrates a simplified block diagram of the return path within a node:

Figure 2.2

Node return path

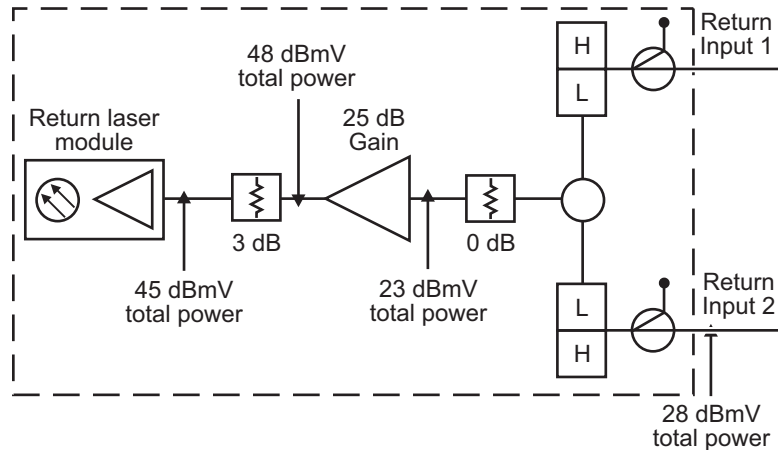

Figure 2.2 identifies two levels that are significant: (1) the return path input level at the station port (28 dBmV) and (2) the level at the laser module or transmitter (45 dBmV). The difference between these levels is the node return gain. In this example, the required node return gain is $45 - 28 = 17$ dB. These two absolute levels (input and transmitter) will probably not be used in the setup process, but the node return gain will be used. This example shows

that a 3 dB pad must be added to the return path inside the node station to give the station a gain of 17 dB. Usually, this pad is placed after the amplifier hybrid so that the noise performance of the node is not affected.

Both the amplifier station input level and the laser transmitter module input level must be known to calculate the node return gain. The node return gain is used in the setup process.

In some cases, all the return path gain blocks are in the laser transmitter and none are in the node. In such cases, the node return gain is a negative number.

Carrier to Noise Ratio and Distortion

Once the plant and optical link levels are chosen, the expected c/n and distortion performance of the plant should be calculated. Such a computation is beyond the scope of this document; however, the procedures outlined thus far should provide an optimal design. The methods used in this document keep plant levels as high as possible; therefore, to obtain better c/n in the RF plant, you must (1) reduce the losses and/or plant variances or (2) increase the available transmitter power of all services.

Summary

Reminder: The goal in selecting the plant operating levels is to keep them as high as possible. The procedures for determining the proper levels are summarized as follows:

1. Choose the desired laser transmitter total power — refer to Levels in the Optical Link—Constant Power per Hz, above.
2. Choose the plant level that is optimal for all services — refer to *Choosing the Best Plant Level* on page 2-7, and Table 2.6.
3. Calculate the total power in the plant for the levels chosen in Step 2. Refer to Table 2.6.
4. Subtract Step 3 from Step 1 to determine the required node return gain.

Unity Gain

What is unity gain and why is it important? Unity gain refers to making the gain of each amplifier station exactly equal to the combined total loss between and inside the stations. Because the loss equals the gain, the net gain from station to station is 0 dB. The term “unity” refers to the number one; therefore, a gain of 1 is another way of saying a gain of 0 dB. Figure 2-3 illustrates forward path signal levels and the concept of unity gain:

Figure 2.3

Unity gain diagram

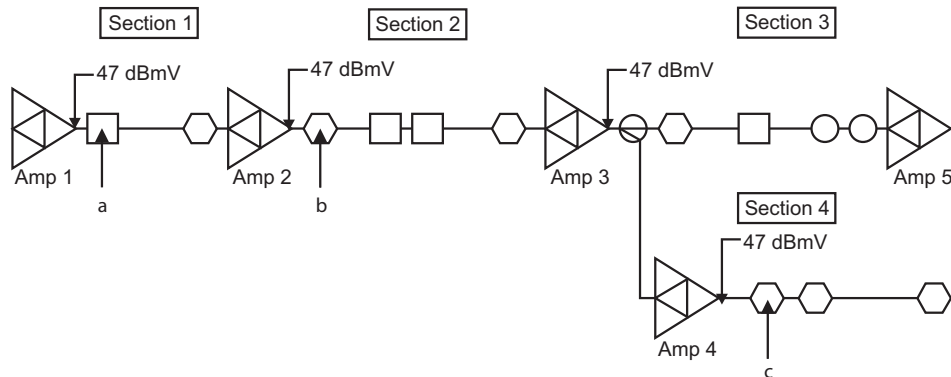

Figure 2.3 indicates that, at the highest channel, the output level is +47 dB at each amplifier station. Because all stations are set to the same level, the gain from one station’s output to the next station’s output is 0 dB, or “unity” gain. During forward path setup, the gain of each station is adjusted so that it exactly matches the loss of the cable and passives that preceded it.

Why is it important to have unity gain? In the forward path, unity gain ensures that the same level comes out of each amplifier. When the system is designed, the tap values are chosen with the assumption that every amplifier has the same output level. Because the tap values are chosen to provide a consistent loss between the output of each amplifier and each tap port, the return path should have the same relationship between the level hitting a tap port and the level at the amplifier.

As an example, assume that amplifiers 1, 2, and 4 in Figure 2.3 are followed immediately by a 26 dB tap. Further assume that the homes connected to these taps have a set-top terminal transmitting at the proper level to provide 36 dBmV at the tap port. As a result, each set-top terminal provides 10 dBmV at the amplifier station, which in turn provides 10 dBmV at the headend.

To identify the consequences of a plant that is not set to unity gain, the following example is used. Assume that the gain at Section 2 is 5 dB too low. The signals injected at points “a” and “b” still arrive at the headend at 10 dBmV. However, the signal injected into point “c” was denied 5 dB of gain on its way to amplifier 2. It arrives at amplifier 2 and continues to the headend as 5 dBmV; thus the level is 5 dB less than the required 10 dBmV.

A return path that is not set for unity gain can display distortion or poor c/n caused by:

- Nonadjustable set-top terminals, or other equipment, that contribute signals to the laser at the wrong level.

- Set-top terminals that are adjustable but are out of adjustment range.

If the designer wants such a gain error to exist, then all other levels in the system must be backed-off by the same amount of error, forcing the plant to operate closer to noise and ingress.

Pads and Equalizers

In the forward path, equalization and padding occur at the input of the station to compensate for the cable and other preceding losses because one unique path exists from the input of the station back to a single station that sent the signals. At the output, multiple paths could go to multiple stations that are the recipients of the signals from this single station. It is impossible to independently adjust the levels to multiple paths from the output of the current station. Referring to Figure 2.3, note that amplifier 3 feeds both amplifier 4 and 5. Although these amplifiers have only one amplifier feeding them, losses to both cannot be adjusted at the output of amplifier 3.

In the return path, the situation is the opposite. Each amplifier drives only a single unique path toward the headend. However, multiple amplifiers can feed into one particular amplifier; therefore, compensating for the path that feeds into an amplifier is not possible. Instead, the amplifier must compensate for the path that it is feeding into. Again using Figure 2-3 as an example, if amplifier 3 is being aligned, it is not possible to simultaneously correct for the loss and equalization of the paths from amplifier 4 and 5. However, it is possible to correct for the loss and equalization of the path from the output of amplifier 3 to the input of amplifier 2. Similarly, both amplifier 4 and 5 can be independently corrected for their own paths towards amplifier 3 by padding and equalizing at their outputs.

If padding and equalizing occur at the output of an amplifier, why is there a pad location at the input in the return path? It exists mainly for the convenience and versatility of measuring or injecting signals. Some designers advocate the use of input pads to reduce ingress. Their goal is to operate set-top terminals at as high a level as possible to get above ingress. Because these levels are very high, a pad is inserted before the return path gain stage of the amplifier. When an input pad is used, the plant is still set up and aligned in the same way. The only difference is that every return path amplifier in the cascade needs to overcome the additional loss of the input pad in the station it feeds.

ARRIS does not normally recommend the use of input pads. As explained previously, levels should be chosen to keep the terminal equipment running at as high a level as possible. It is not necessary to pad the input of a hybrid amplifier type of gain stage because it cannot be overdriven by present terminal equipment drive levels. Higher drive levels from the terminal equipment in the home are unlikely as they lead to increased power consumption and equipment costs, as well as possibly cause crosstalk problems within the home.

Location

The need for unity gain between amplifier stations has thus been established. What has not yet been determined is where, inside the amplifier station, the unity gain point resides. In general, the industry recognizes two unity gain locations: (1) the input to the amplifier module and (2) the input to the station housing. Alignment must be performed at the proper unity gain location or distortion and poor c/n, similar to improper plant gain adjustment, will be observed. Selecting the input to the return amplifier as the unity gain point optimizes the plant for noise performance while selecting the station housing optimizes the plant for levels.

This guide suggests that the best unity gain point is the station's output port or, more specifically, the station's output diplex filter (return path input diplex filter). Block diagrams of two very different types of amplifiers are used to clarify this position. Figure 2.4 illustrates a typical line extender, such as the Broadband Line Extender (BLE), and Figure 2.5 illustrates a distribution amplifier, such as the Broadband Telecommunications Amplifier (BTD). For simplicity, the diplex filters are assumed to have zero loss in both examples.

Figure 2.4

Line extender

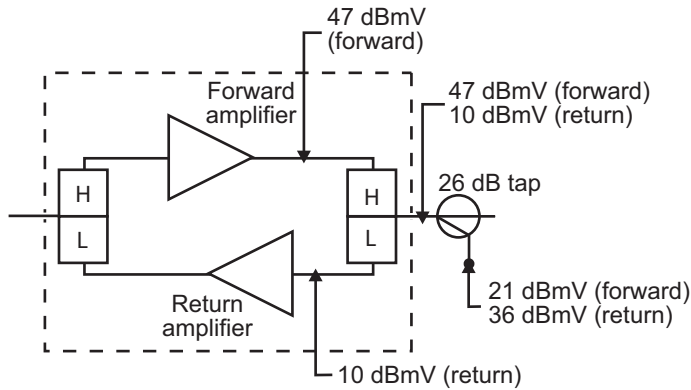

Figure 2.5

Distribution amplifier

2

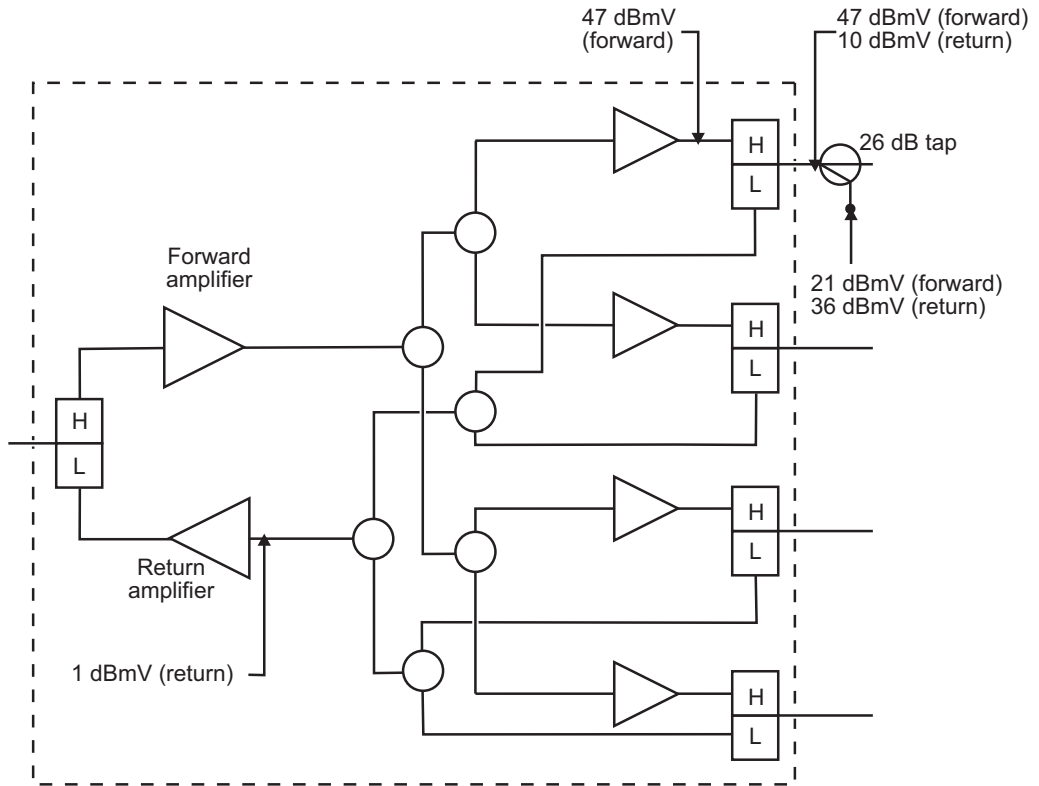

Figure 2.4 and Figure 2.5 show a signal being injected into a 26 dB tap that is connected to the station's output port (see *note* below). In both cases, the injected signal is 36 dBmV at the tap port. After passing through the 26 dB loss of the tap, both signals arrive at the diplex filter at 10 dBmV. Because a constant level is required at every output diplex filter, the plant is properly aligned. In other words, 36 dBmV is required at a 26 dB tap, regardless of the amplifier type.



Note Multiple station output ports are often labeled *OUT*, *1*, *2*, and so forth. When the term "output port" is used in this guide, it refers to any forward path station output port.

If the definition of the unity gain point is the return hybrid input instead of the diplex filter, the level at the hybrid input is constant for all types of amplifiers. In this situation, the line extender requires no change because of the negligible loss between the diplex filter and the hybrid input. However, the distribution amplifier operates at very different levels, as illustrated in Figure 2.6:

Figure 2.6

Distribution amplifier with incorrect levels

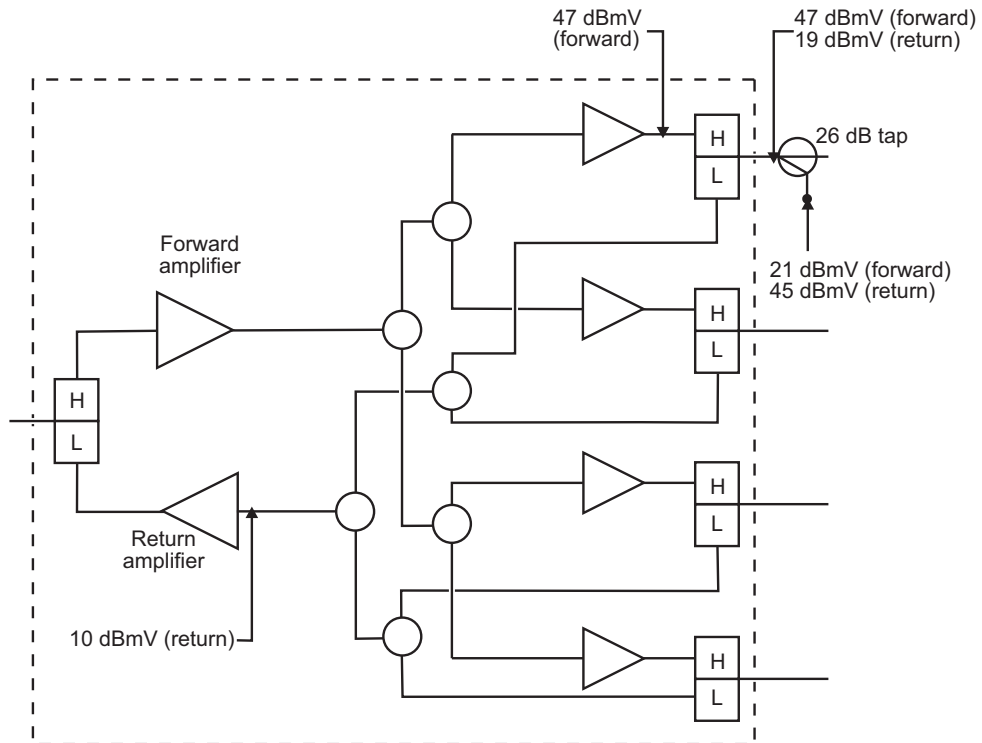

With the unity gain point at the hybrid input, a particular level in the headend is produced as a result of a constant (unity gain) level at each hybrid input. Using Figure 2.6 as an example, 10 dBmV at each hybrid produces a level of 10 dBmV in the headend. This requires the terminal equipment to transmit at a higher level to get into a distribution amplifier. Figure 2-6 indicates that a level of 19 dBmV is required at the port to produce a level of 10 dBmV at the hybrid input. As a result, the terminal equipment feeding the distribution amplifier needs to be 9 dB higher than the same equipment feeding a line extender. It is undesirable to require the terminal equipment to transmit at different levels just because the particular tap fed by that equipment follows a different style of amplifier. Plant levels are designed so that terminal equipment operates at maximum level. Any additional gain variance requires that the nominal plant levels be lowered. This example denotes that nominal plant levels must be lowered 9 dB if the unity gain point is assigned to the hybrid amplifier's input instead of the diplex filter.

While this guide refers to the diplex filter as the best unity gain location, this statement can be simplified by restating that the best unity gain location is the station return input port (same as the station output port). An exception to this simplification is station topologies that provide plug-in options between the diplex filter and the station port, as illustrated in Figure 2.7.

Figure 2.7

Amplifier with
plug-in option at
output

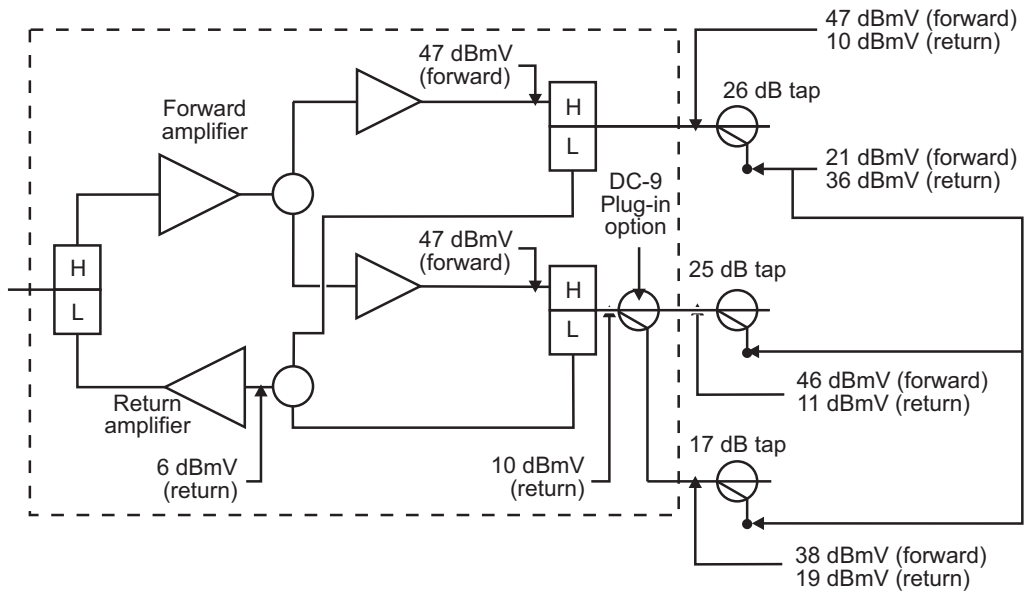

Because such an option “behaves” like feeder loss, it needs to be treated like feeder loss. The plug-in option illustrated in Figure 2.7 is the DC-9 directional coupler. The coupler is assumed to have a 1 dB loss in the through-leg and a 9 dB loss in the coupled-leg. Figure 2.7 denotes that the tap value selected for the feeder is different because of the coupler (a 25 dB tap is used for example purposes and simplicity even though it may not actually exist). The different tap value is selected so that the forward level at the tap port is constant (21 dBmV in the example). Similarly, a 17 dB tap is selected for the feeder fed by the tapped leg of the directional coupler to maintain a constant forward level at the tap port. The figure also shows a constant return path injection level of 36 dBmV into each tap port since each house should have the same nominal design level. With the addition of the DC-9 coupler, the return path levels at the station are different depending on which leg of the coupler is being measured. However, the level at the diplex filter remains the same at 10 dBmV.

We hope that these examples satisfactorily explain our contention that the best location of unity gain is the station output diplex filter. However, if no significant losses occur between the filter and the station port, the unity gain point can be synonymous with the station port.

Having plug-in options at the output is just one of many unique designs that can be encountered. Additional designs are presented in Appendix A, *Other Conditions*.

ALIGNMENT

This section examines the approach used, and identifies the equipment and procedures required for successful alignment of the return plant.

Strategy

In this reference guide, the strategy used for alignment of the return path is referred to as the “round-robin” approach. This concept places a piece of receiving equipment at the headend to monitor the signals being received from the return plant. This equipment then sends the information back out into the plant through the forward path in one of two ways:

- The signals arriving at the headend from the return plant can be monitored by a spectrum analyzer. The display on the analyzer is then placed on a forward path channel using a forward path modulator. The video signal for the forward path is obtained by aiming a TV camera at the spectrum analyzer display or by using the composite video output connector on the spectrum analyzer. Using a tone generator to inject a signal into the plant, the technician can then observe the spectrum analyzer’s output on a portable TV. When this method is used, be careful to use sufficient tones so that the frequency response of the return system is accurately monitored. At least four tones in a 35 MHz bandpass are recommended for this purpose.
- The signals arriving at the headend can be analyzed by a sweep system. Several manufacturers make systems that consist of hand-held units for field work and rack-mount units for the headend. The field unit puts out signals that are received in the headend. The unit in the headend analyzes these signals and sends the display information into the forward path in a narrow-band digital signal. This digital signal is detected by the field unit and displayed.

Figure 3.1 illustrates the “round-robin” approach:

Figure 3.1

Round-robin setup

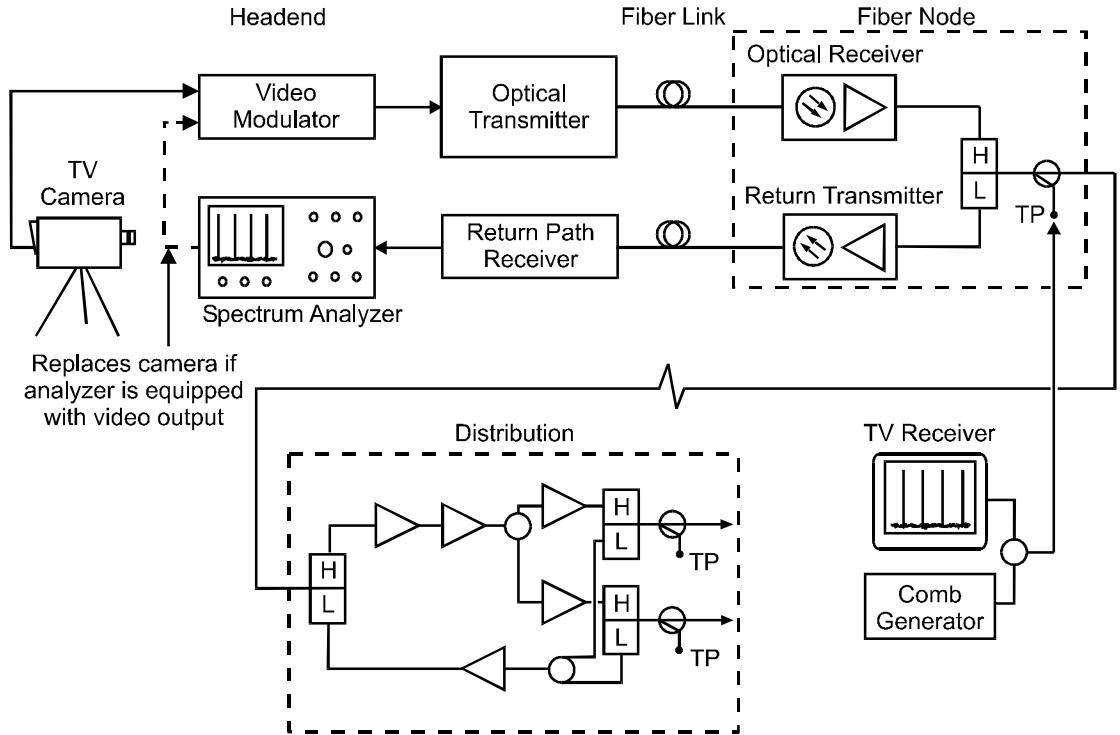

Regardless of whether a sweep system or a spectrum analyzer is used, the procedure for aligning the return path is the same. As Figure 3.1 illustrates, the starting point is the insertion of the signal into the node station. In general, the first injection point is directly into the laser transmitter to verify the optical link gain. The injection point is then moved to the station's output port (output diplex filter) to set the node return gain. Refer to Chapter 2, *Node Return Gain* to review the procedure for calculating the required gain. If the node return gain is not correct, it should be adjusted at this time by adding gain or loss between the station port and the laser transmitter. When the node return gain is set correctly, the present overall gain reading is memorized as the desired unity gain level. The field technician now moves out into the cascade one station at a time and injects the same level at the amplifier station's output port as at the node station's output port. The amplifier station's return path output pad and equalizer are then adjusted to bring the level as close as possible to the memorized unity gain level. This procedure is described in greater detail in subsequent sections.

Signal Levels Versus Gains and Losses

In addition to the choice of strategies described previously, two different methodologies can be used to align the return path. One is to think of signal levels and the other is to think of gains and losses. The procedures explained later in this section under *Optical Link Level and Gain Tables* on page 3-5 focuses on the relative merits of each approach and which method is most useful at the time. In general, the gain/loss approach seems easier to understand and use due to the fact that modern sweep systems are designed to provide normalized gain sweeps and are not as well suited to absolute signal level measurements.

Insertion Point

Before beginning the actual alignment procedure, it is necessary to review where to inject signals into the amplifier and node stations. The importance of choosing the output diplex filter as the unity gain point for aligning the return path was discussed earlier. This task would be easy if all the stations had a test point at the diplex filter. Although some do not, it is not difficult to correct for the loss between the available test point and the diplex filter. The BTD amplifier is used to explain the correction process and is illustrated in Figure 3.2.

Figure 3.2

BTB block diagram

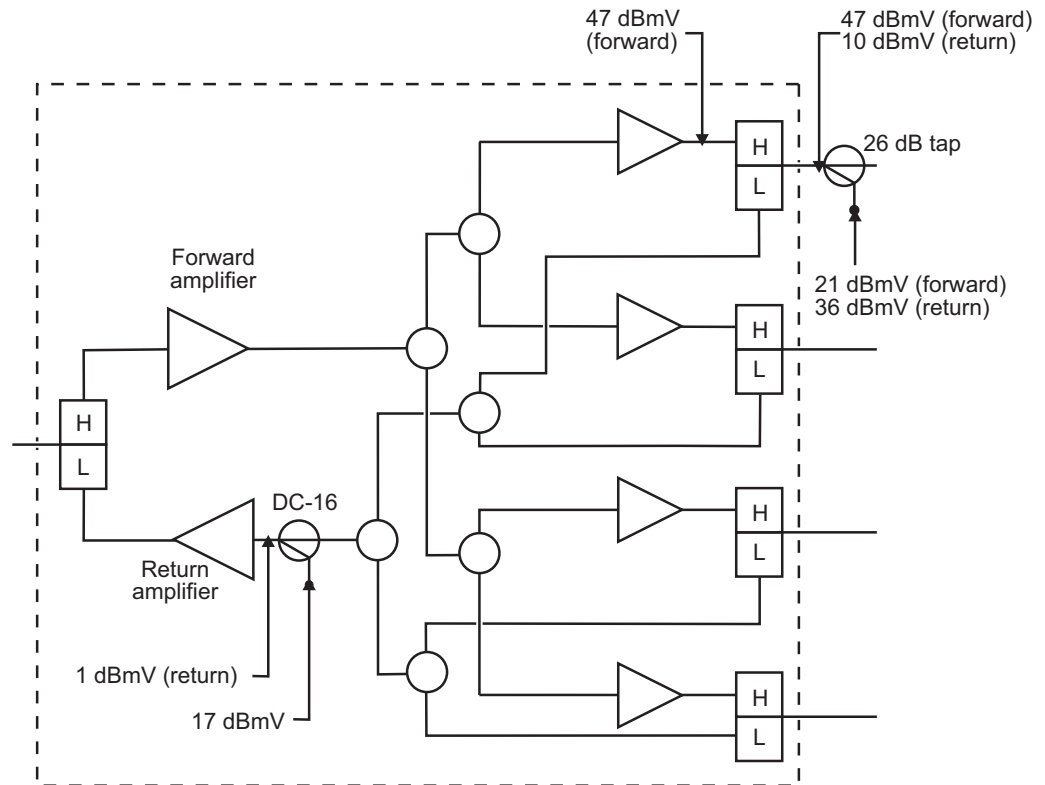

Assume that the desired injection level is 10 dBmV at the diplex filter. You can calculate that if 10 dBmV is present at the diplex filter, then 1 dBmV is present at the hybrid. The available test point is through a 16 dB directional coupler at the input of the return path hybrid amplifier. The proper level to be injected into the directional coupler to obtain 1 dBmV at the hybrid is 17 dBmV. As a result, the injection signal should be 7 dB higher than the desired unity gain level (17 dBmV injected minus 10 dBmV desired). The BTB amplifier, listed in Table 3.1, can be used as an example of these losses.

It is not necessary to go through these calculations every time an amplifier is aligned. Table 3.1 identifies the injection point locations and provides necessary details regarding what the level should be, and the losses incurred for many common amplifiers. The "insertion point loss" column shows how much higher the injection signal level should be over the desired level at the unity gain point.

Table 3.1 Insertion point locations and losses

Model	Insertion Point	Test Point Loss	Loss Between Duplex Filter and Test Point	"Insertion Point Loss" (Actual Loss Relative to Duplex Filter)
Nodes				
SG2	Output test point	20	0	20
BTN	Status monitor connector	16	9	7
MBR	Output test point	20	0	20
MBR	JXP before return hybrid	0	4	-4
SX	Return test point	20	1	19
SX	Feeder maker test point	30	0	30
Amplifiers				
BTD	Status monitor connector	16	9	7
MB	Output test point	20	0	20
MB	JXP before return hybrid	0	4	-4
BLE	Test point before return hybrid	20	0	20
BLE	JXP before return hybrid	0	1	-1
BLE-*/*	Output test point	20	0	20
JLX	Output test point	30	0	30
JLX	JXP before return hybrid	0	1	-1
SX	Return test point	20	1	19
SX	Feeder maker test point	30	0	30



Note Some of the "Insertion Point Loss" numbers are negative. In these cases, there is a net gain between the insertion level and the equivalent level at the duplex filter.

Compensating for Insertion Point Loss

If a sweep system is employed, the "Insertion Point Loss" figures given in Table 3.1:

1. When loss can be entered — enables the user to inform the system of the loss value by entering the "Insertion Point Loss" directly from the table.

2. When loss cannot be entered — enables the plant to be correctly adjusted to unity gain when the sweep gain is below the unity gain reference sweep by the same amount as the “Insertion Point Loss” given in the table. This is used when the sweep system does not enable the insertion point loss to be entered as a correction factor thus causing the display of a *lower* gain. When the unity gain reference sweep is memorized at the node station, ensure that it is *higher* than the actual sweep by the value indicated in the “Insertion Point Loss” column.

If tones are used, they should be raised by the amount of the “insertion point loss” value given in Table 3.1 before inserting them into the system. This rule should be observed both at the node and at all RF amplifiers in the plant.

Optical Link Alignment

Before aligning the optical links, it is important to understand why they all need to have the same gain. Remember, our goal is to have unity gain throughout the entire plant. We discussed previously how to make all amplifiers and nodes achieve unity gain. We must also consider the optical link between the node and the headend. It is not sufficient to merely have all the laser transmitters driven by the correct RF levels; they must also have the same gain to the headend. Unity gain throughout the plant is impossible if different gains exist between various nodes and the headend.

Unity Gain Between Optical Links

The first step is to determine which link has the lowest levels. In general, this is the link with the most optical loss. An exception is when different power lasers are used in the same plant. If we assume that the lowest output level corresponds to the longest optical link, we can measure the loss of that link and use it as the reference. It is easiest to align this link first but we assume that other factors such as location or priorities make that inconvenient.

Once the link with the lowest levels is identified, it is used as the basis for determining the desired link gain. All of the other links, which have higher net gains, will be padded down to equal the long link. In some cases not just one, but several links, are longer than the majority of the links in the system. In this case, it is undesirable to use a rare, very low link, as the reference. A more representative link should be chosen as the reference and gain added to the very long links to bring them up to that reference.

Optical Link Level and Gain Tables

As mentioned previously in *Signal Levels Versus Gains and Losses* on page 3-2, plant alignment can be thought of in terms of levels or gains. Levels are useful because they relate to the services that occupy the return path. Gains are useful because the sweep equipment is designed to show gains. Table 3.2 shows the laser transmitter module input levels and Table 3.3 shows the expected fiberoptic receiver output levels that correspond to the various transmitters. All levels represent total power and are given in dBmV.

Table 3.2 Laser module input levels

Node Model	SX			MBR and BTN			SG 2000		OmniStar
Laser Model	AM-RPTD	AM-RPTV1	AM-RPTV4	AM-MB-RPTD	AM-BTN-RPTV1	AM-TC-RPT	SG2-DFBT	SG2-IFPT	AM-OMNI-RPT
Input Level	20	25	25	40	45	45	15	15	15

Table 3.3 Receiver output levels

Optical Link Loss	AM-RPTD	AM-RPTV1	AM-RPTV4	AM-MB-RPTD	AM-BTN-RPTV1	AM-TC-RPT	SG2-DFBT	SG2-IFPT	AM-OMNI-RPT
0	48	48	61	48	48	48	51	48	57
1	46	46	59	46	46	46	49	46	55
2	44	44	57	44	44	44	47	44	53
3	42	42	55	42	42	42	45	42	51
4	40	40	53	40	40	40	43	40	49
5	38	38	51	38	38	38	41	38	47
6	36	36	49	36	36	36	39	36	45
7	34	34	47	34	34	34	37	34	43
8	32	32	45	32	32	32	35	32	41
9	30	30	43	30	30	30	33	30	39
10	28	28	41	28	28	28	31	28	37
11	26	26	39	26	26	26	29	26	35
12	24	24	37	24	24	24	27	24	33

The output levels given in Table 3.3 are typical output levels for an AM-RPR optical receiver. The AM-OMNI-RPR/2 receiver has a minimum gain adjustment range of ± 8 dB and typically ± 10 dB from the levels given above. Both receivers have the best distortion performance when operated below 40 dBmV total output power. Performance starts to degrade between 40 dBmV and 50 dBmV — indicated by output levels in italics. The receivers should not be operated above 50 dBmV output — indicated by output levels in bold italics.

Table 3.2 and Table 3.3 are consolidated into Table 3-4 to show the optical link gain from the transmitter input to the receiver output.

Table 3.4 Optical link gain

Optical Link Loss	AM-RPTD	AM-RPTV1	AM-RPTV4	AM-MB - RPTD	AM-BTN-RPTV1	AM-TC RPT	SG2 DFBT	SG2 IFPT	AM-OMNI-RPT
0	28	23	36	8	3	3	36	33	42
1	26	21	34	6	1	1	34	31	40
2	24	19	32	4	-1	-1	32	29	38
3	22	17	30	2	-3	-3	30	27	36
4	20	15	28	0	-5	-5	28	25	34
5	18	13	26	-2	-7	-7	26	23	32
6	16	11	24	-4	-9	-9	24	21	30
7	14	9	22	-6	-11	-11	22	19	28
8	12	7	20	-8	-13	-13	20	17	26
9	10	5	18	-10	-15	-15	18	15	24
10	8	3	16	-12	-17	-17	16	13	22
11	6	1	14	-14	-19	-19	14	11	20
12	4	-1	12	-16	-21	-21	12	9	18

A gain table is useful when using a sweep setup; however, it does not give any indication of how high the signal levels can be. The output chart (Table 3.3) should be consulted to be certain that the fiberoptic receiver is not overdriven.

Alignment Procedure

The procedures and instructions presented in the following subsections enable you to perform all the tasks required to align individual nodes and return amplifiers and incorporate them into an operational return path system. A list of the abbreviations, acronyms and definitions of the special terms used in this section are provided in the Appendix D, *Glossary*.

Reference Level Calculations

The special terms used in this subsection include:

- Reference link gain
- Reference link output level
- Maximum link output level

To calculate the reference levels:

1. Determine the maximum link output level. Unless otherwise specified, a maximum link output level of +50 dBmV can be used. The AM-RPR and AM-OMNI-RPR/2 have the best distortion performance when operated below 40 dBmV total output power. Performance degrades between 40 and 50 dBmV and the units should not be operated above 50 dBmV.
2. Determine the reference link gain using Table 3.4. Find the column that corresponds to your model transmitter and the row that matches the optical link loss that you chose for your reference link gain. The intersection of that column and row is your reference link gain which is the desired gain between the transmitter module input (in the node) and the optical receiver output (in the headend). Typically, the reference link gain chosen is the gain of the longest link.
3. Determine the reference link output level using Table 3.3. Find the column that corresponds to your model transmitter and the row that matches the optical link loss that you chose for your reference link gain. The intersection of that column and row is the reference link output level.
4. Record the maximum link output level, reference link gain, and reference link output level in the original levels column in Table 3.5.

Table 3.5 Alignment levels

	Original levels	Reduced levels (if required)
Maximum link output level		N/A
Reference link gain		
Reference link output level		

5. Compare the reference link output level to the maximum link output level. If the reference is less than the maximum, proceed to the next procedure "Optical Link Alignment." If the reference is greater than the maximum proceed as follows:

Calculate the required link gain reduction by subtracting the maximum link output level from the reference link output level.

Subtract the link gain reduction from the reference link gain and enter the result as the reference link gain in the reduced levels column.

Subtract the link gain reduction from the reference link output level and enter the result as the reference link output level in the reduced levels column. The new reference link output level should equal the maximum link output level.

Use the values listed in the reduced levels column for the remainder of the alignment procedure.

Optical Link Alignment

The special term used in this subsection includes: Link gain.

To align the optical link:

1. Connect the sweep equipment to the node being aligned. Inject the tones or sweep signal directly into the laser transmitter module in the node station.

If a sweep system is used, the absolute injection level into the laser transmitter is not critical since we are only concerned with the gain of the link, not absolute levels. However, the injection level must be in the linear operating region of the transmitter and be sufficiently above the noise floor. The power of the sweep signal should not exceed the laser module input levels given in Table 3.2.

If tones are used, the total power of the tones should be equal to the laser module input levels given in Table 3.2. For a multiple tone injection source, the level per tone should be set equal to:

Level per tone = total power -10* log (number of tones)

For example, a four-tone injection needs each of its four tones set 6 dB lower than the desired total power.

Table 3.6 provides the calculation for the proper level for two through ten tones.

Table 3.6 Level per tone

Number of Tones	Level Per Tone (dB)
2	-3.0
3	-4.8
4	-6.0
5	-7.0
6	-7.8
7	-8.5
8	-9.0
9	-9.5
10	-10.0

2. Measure the link gain using one of the following methods:

If a sweep system is used, the link gain is displayed directly.

If tones are used, the link gain is equal to the output level minus the input level:

link gain = output level - input level

3. Compare the output level or link gain to Table 3.3 or Table 3.4 as appropriate. This comparison requires that you know the optical loss of this particular link. This number can be determined either by an actual loss measurement (measured with a power meter) or by subtracting the received optical power (measured at the receiver’s optical power test point) from the transmitter output power. If the levels are not as expected, troubleshoot for the cause.
4. Reduce the gain of this link by padding to match the reference link gain and to have an output which is not greater than the maximum link output level. With an AM-OMNI-RPR/2, this is done with the front panel gain control, or with external in-line RF pads. In the AM-OMNI-RPR/2, gain changes 0.5 dB each time the gain

control button is pressed. If the receiver is at the end of its gain control range, the NORM LED on the front panel flashes in response to an attempted gain change. With the AM-RPR, this is done with an internal JXP pad or external in-line pads.

First compare the output level of this link to the maximum link output level determined in *Reference Level Calculations* on page 3-7. Find the output level in Table 3.3 that corresponds to the current optical link loss and transmitter model in use. Compare this output level to the maximum link output level. If the level given in Table 3.3 is greater than the maximum link output level, reduce the gain of the AM-OMNI-RPR/2 by the difference or put an internal pad of the same value in the AM-RPR. External in-line pads should not be used in this step.

Next, any additional loss required to match the reference link gain can be accomplished by further internal gain reduction or by using external in-line pads. Typically, external pads provide superior noise performance.



Note *If using a sweep system for alignment, the actual levels are invisible to the operator. When performing Step 4, ensure that the actual operating levels are not greater than desired. The same caution applies to alignment using tones as the level of any one tone is only a fraction of the total system power.*

5. Confirm that the link gain is equal to the reference link gain.

Setting the Node Return Gain

The special terms used in this subsection include:

- Node return gain
- Node return full gain
- Unity gain reference sweep

This section describes the procedure used to verify that the node return gain matches the desired node return gain. The injection point is moved from the transmitter module input to the node station return path input (output diplex filter) by completion of the following steps:

1. Connect the sweep system to the desired node. Set the link gain to the reference link gain using the procedure described in *Optical Link Alignment* on page 3-8.
2. Compare the node return full gain (typically given in specification sheets) to the desired node return gain. Subtract the node return gain from the node return full gain to get the node pad value. For future reference record these values in the spaces provided below:

Node return full gain _____

Node return gain _____

Node pad value _____

Place a pad equal to the node pad value between the station port and the laser module. The preferred location for this pad is between the hybrid amplifier and the laser module, if the node is so equipped.

Inject the tones or sweep signal into the station output port (or into an appropriate injection point as described in *Insertion Point* on page 3-3). If an injection point is used, correct for the loss of the injection point as follows:

If using a sweep system, the absolute injection level of the signal into the injection point is not critical since we are concerned primarily with the gain of the link. However, the injection level must be in the linear operating region of the transmitter and must be sufficiently above the noise floor. The power of the sweep signal at the laser should not exceed the laser module input levels given in Table 3.2. The formula below reminds us that the sweep signal must go through the insertion point loss and the node return gain on its way to the transmitter.

Maximum injection level = laser module input level - node return gain + insertion point loss

If the sweep system compensates for insertion point loss, enter the loss value into the sweep system. If it does not automatically compensate for loss, you must correct for it by using equations provided later in this guide.

If using tones, the total power of the tones at the laser module must be equal to the laser module input levels given in Table 3.2. Tones are also subject to level changes as indicated by the formula below:

Injection level = laser module input level - node return gain + insertion point loss

Injection level refers to the total power at the injection point. The signal injected usually consists of several tones. For a multiple injection source, the level per tone can be determined from Table 3.6

3. Compare the gain of the sweep to the reference link gain. The difference should equal the node return gain.

If using a sweep system with the ability to compensate for the insertion point loss use the following equation:

Node return gain = present gain - reference link gain

If the sweep system cannot automatically compensate for the insertion point loss, use the following equation:

Node return gain = present gain - reference link gain + insertion point loss

If tones are used, the following equation applies:

Node return gain = output level - input level - reference link gain + insertion point loss

The input level in the equation above is the actual level injected into the insertion point.

4. If the node's return gain does not match the desired node return gain, adjust the pad values to compensate.

Record the unity gain reference sweep as follows:

When using a sweep system with automatic compensation for insertion point loss, save the present sweep as the unity gain reference sweep.

When using a sweep system that does not automatically compensate for insertion point loss, the correct unity gain reference sweep is *higher* than the displayed sweep by the amount of the insertion point loss. Add the insertion point loss to the displayed sweep (the method used depends on the type of sweep system) and record the corrected sweep as the unity gain reference sweep. This is summarized in the equation below:

Unity gain reference sweep = displayed sweep + insertion point loss

When using tones, the unity gain reference sweep is the output level out of the fiberoptic receiver minus the level of the injected tones plus the insertion point loss as indicated in the equation below:

Unity gain reference sweep = output level – input level + insertion point loss

The unity gain reference sweep just defined will be used as the reference at every subsequent amplifier station.

Combined Node Return Gain and Optical Link Alignment

At the users' discretion, the two previous procedures can be combined into one. The combined procedure has an associated advantage and disadvantage. The advantage is that unlike the optical link alignment procedure, which uses injection directly into the laser module with subsequent disruption of service, the combined procedure can be performed through test points and disruption of service is avoided. The disadvantage is that the node return gain cannot be set as accurately.

To perform the combined procedure:

1. Calculate the reference levels using the procedure described in *Reference Level Calculations* on page 3-7.
2. Compare the node return full gain (typically given in specification sheets) to the desired node return gain. Subtract the node return gain from the node return full gain to get the node pad value. For future reference record these values in the chart below:

Node return full gain_____

Node return gain_____

Node pad value_____

Place a pad equal to the node pad value between the station port and the laser module. The preferred location for this pad is between the hybrid amplifier and the laser module, if so equipped.

3. Inject the tones or sweep system into the station output port (or into an appropriate injection point as described in *Insertion Point* on page 3-3). If an injection point is used, correct for the loss of the injection point as follows:

If using a sweep system, the absolute injection level of the signal into the injection point is not critical since we are concerned primarily with the gain of the link. However, the injection level must be in the linear operating region of the transmitter and must be sufficiently above the noise floor. The power of the sweep signal at the laser should not exceed the laser module input levels given in Table 3.2. The formula below reminds us that the sweep signal must go through the insertion point loss and the node return gain on its way to the transmitter.

Maximum injection level = laser module input level – node return gain + insertion point loss

If the sweep system compensates for insertion point loss, enter the loss value into the sweep system. If it does not automatically compensate for loss, you must correct for it by using equations provided later in this guide.

If using tones, the total power of the tones at the laser module should be equal to the laser module input levels given in Table 3.2. Tones are also subject to level changes as indicated by the formula below:

Injection level = laser module input level – node return gain + insertion point loss

Injection level refers to the total power at the injection point. The signal injected usually consists of several tones. For a multiple injection source, the level per tone can be determined from Table 3.6.

4. Calculate the link gain by using the appropriate equation:

If using a sweep system with automatic compensation for insertion point loss:

Link gain = displayed sweep – node return gain

If using a sweep system that does not compensate for insertion point loss:

Link gain = displayed sweep – node return gain + insertion point loss

If tones are used:

Link gain = output level – input level – node return gain + insertion point loss

5. Compare the output level or link gain to Table 3.3 or Table 3.4 as appropriate. This comparison requires that you know the optical loss of this particular link. This number can be determined either by an actual loss measurement (measured with a power meter) or by subtracting the received optical power (measured at the receiver's optical power test point) from the transmitter output power. If the levels are not as expected, troubleshoot for the cause.
6. Reduce the gain of this link by padding to match the reference link gain and to have an output which is not greater than the maximum link output level. With an AM-OMNI-RPR/2, this is done with the front panel gain control, or with external in-line RF pads. In the AM-OMNI-RPR/2, gain changes 0.5 dB each time the gain control button is pressed. If the receiver is at the end of its gain control range, the NORM LED on the front panel flashes in response to an attempted gain change. With the AM-RPR, this is done with an internal JXP pad or external in-line pads.

First compare the output level of this link to the maximum link output level determined in *Reference Level Calculations* on page 3-7. Find the output level in Table 3.3 that corresponds to the current optical link loss and transmitter model in use. Compare this output level to the maximum link output level. If the level given in Table 3.3 is greater than the maximum link output level, reduce the gain of the AM-OMNI-RPR/2 by the difference or put an internal pad of the same value in the AM-RPR. External in-line pads should not be used in this step.

Next, any additional loss required to match the reference link gain can be accomplished by further internal gain reduction or by using external in-line pads. Typically, external pads provide superior noise performance.



Note *If using a sweep system for alignment, the actual levels are invisible to the operator. When performing Step 6, ensure that the actual operating levels are not greater than desired. The same caution applies to alignment using tones as the level of any one tone is only a fraction of the total system power.*

7. Confirm that the link gain is equal to the reference link gain.
8. Record the unity gain reference sweep as follows:

When using a sweep system with automatic compensation for insertion point loss, save the present sweep as the unity gain reference sweep.

When using a sweep system that does not automatically compensate for insertion point loss, the correct unity gain reference sweep is higher than the displayed sweep by the amount of the insertion point loss. Add the insertion point loss to the displayed sweep (the method used depends on the type of sweep system) and record the corrected sweep as the unity gain reference sweep. This is summarized in the equation below:

Unity gain reference sweep = displayed sweep + insertion point loss

When using tones, the unity gain reference sweep is the output level out of the fiber optic receiver minus the level of the injected tones plus the insertion point loss as indicated in the equation below:

Unity gain reference sweep = output level - input level + insertion point loss

The unity gain reference sweep just defined will be used as the reference at every subsequent amplifier station.

RF Plant Alignment

To verify that every amplifier station has unity gain to the node station:

1. Connect the sweep system to the desired node's output in the headend.
2. Align the gain of the node station and record the unity gain reference sweep as discussed previously.
3. Proceed to the amplifier station that is next in line after the node.
4. Inject the tones or sweep signal into the station output port (or into an appropriate injection point as described in *Insertion Point* on page 3-3). If an injection point is used, correct for the loss incurred as follows:

When using a sweep system with automatic compensation for insertion point loss, enter the insertion point loss value into the sweep system.

When using a sweep system that does not automatically compensate for insertion point loss, a lower gain is displayed. As a result, the plant is correctly adjusted to unity gain when the displayed sweep is below the unity gain reference sweep by the same amount as the insertion point loss.

If tones are used, they should be raised by the amount of the insertion point loss.

5. Compare the displayed sweep to the unity gain reference sweep. Adjust the output pad and equalizer until the closest possible match is obtained between the displayed sweep and the unity gain reference sweep.

If using a sweep system with automatic compensation for insertion point loss, the displayed sweep and unity gain reference sweep can be compared directly.

If using a sweep system that does not automatically compensate for insertion point loss, the plant is correctly adjusted to unity gain when the displayed sweep is below the unity gain reference sweep by the same amount as the insertion point loss. The following equation is true when the plant is adjusted correctly:

$$\text{Unity gain reference sweep} = \text{displayed sweep} + \text{insertion point loss}$$

If tones are used, the following equation is true when the plant is adjusted correctly:

$$\text{Unity gain reference sweep} = \text{output level} - \text{input level} + \text{insertion point loss}$$

6. Record the values of the pad(s) and equalizer for future reference. Remove the alignment signals, close the amplifier, and proceed to the next station.



Note *Never align a station that has an unaligned station between it and the node.*

OTHER CONDITIONS

This section identifies how to deal with other situations that can be encountered and presents unique approaches to proper return plant alignment.

Changes in Forward Levels

A condition may exist where one section of the plant is operated at lower forward levels than the rest of the plant. This means that the tap values are also lower and, consequently, the return input levels are too high. As a result, the transmitters in the home are instructed to turn down their levels. This is undesirable because the transmitter levels will be getting closer to ingress. Alternatively, if the forward levels in a section of plant are higher than the rest of the plant, the tap values are higher and the transmitters get instructed to adjust to higher output levels that some are not able to reach. Our goal is to prevent any section of the plant from requiring different transmitter levels than any other section of the plant. To solve this problem, when forward output levels are different, the return path input level should be changed by the same amount in the opposite direction. Figure A.1 illustrates a line extender which is used as an example:

Figure A.1

Original levels

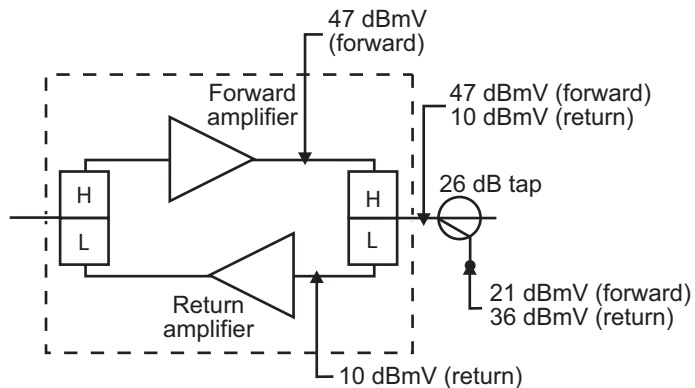

Figure A-2 illustrates a section of the plant where forward path levels are *lowered* to 43 dBmV with the subsequent selection of a lower value tap. When a constant tap port injection level is maintained, the level will be 4 dB too high at the diplex filter. To compensate, the return path level should be aligned 4 dB higher at this station by one of the following methods:

- Manually add 4 dB to the injection signal.
- Accept 4 dB less gain on the sweep.

- Adjust the insertion point loss setting on the sweep system 4 dB lower (if the sweep setup has an insertion point loss setting).
- Subtract 4 dB from the insertion point loss given in Table 3.1 on page 3-4.

Figure A.2

Forward path levels
lowered 4 dB

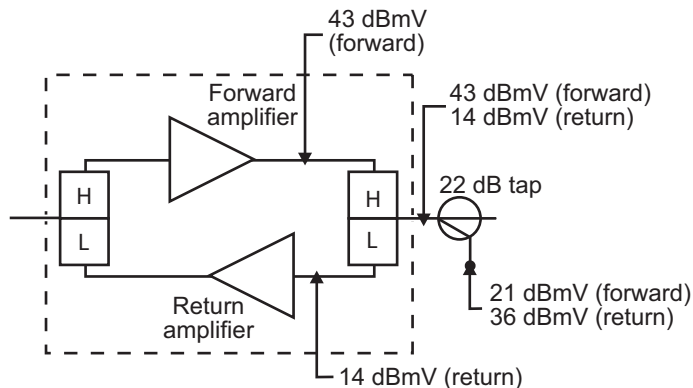

➤ **To summarize:**

If the forward path levels go *down* by x dB, use one of the following four methods for proper return path level compensation:

- Raise the injection signal by x dB.
- Accept x dB less gain on the sweep.
- Adjust the insertion point loss setting on the sweep system x dB lower (if the sweep setup has an insertion point loss setting).
- Subtract x dB from the insertion point loss given in Table 3.1 on page 3-4.

If the forward path levels go *up* by x dB, use one of the following four methods for proper return path level compensation:

- Lower the injected signal by x dB.
- Accept x dB increased gain on the sweep.
- Adjust the insertion point loss setting on the sweep system x dB higher (if the sweep setup has an insertion point loss setting).
- Add x dB to the insertion point loss given in Table 3.1 on page 3-4.

Using Trunk Amplifiers

Trunk amplifiers (and trunk node stations) have separate trunk and bridger output modules. The return paths of these modules are combined either through a combiner or directional coupler. Figure A.3 provides a block diagram of a trunk amplifier.

Figure A.3

Trunk amplifier

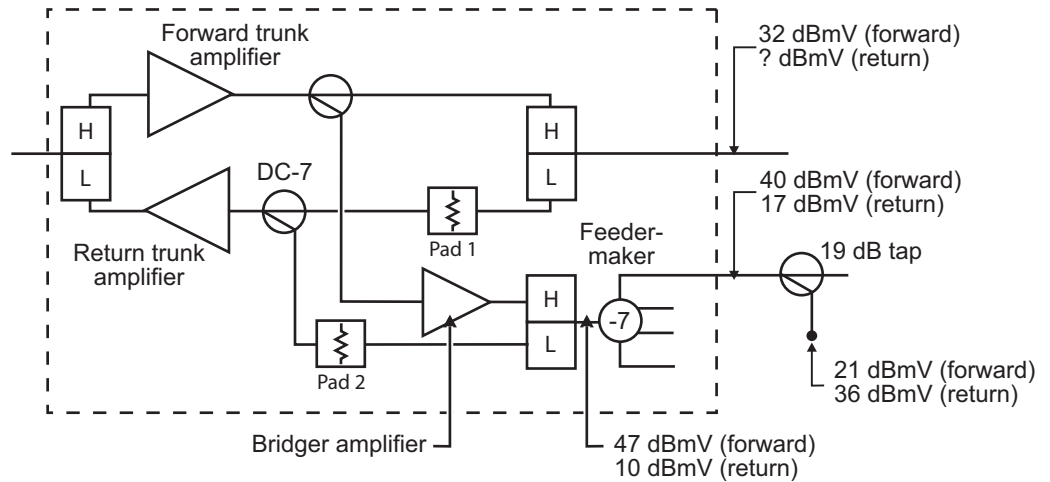

As in previous examples, Figure A.3 indicates 10 dBmV at the unity gain point (diplex filter). If the value of pad 2 is zero dB, then 3 dBmV remains at the return path amplifier after going through the 7 dB directional coupler. It is the trunk output however, that causes the problem. The rules stated in *Changes in Forward Levels* on page A-1 for differing port output levels, require 15 dB more signal at the trunk diplex filter than at the bridger diplex filter because the forward path levels are 15 dB lower. This condition provides 25 dBmV at the diplex filter. Because the signals cannot be independently adjusted once combined, it is necessary to have all the ports hit the hybrid at the same level. Therefore, pad 1 should be 22 dB to get 3 dBmV at the hybrid input. Use of a 22 dB pad is unrealistic thereby necessitating one of the following options:

- Use a bridger gate switch with a gain of 7 dB in the bridger return path (near the pad 2 location). This raises the level at the hybrid to 10 dBmV and lowers the Pad 1 requirement to 15 dB.
- Run the trunk return at a lower level. The ratio of forward to return levels in the cable between stations is only important when there are taps in the cable. Trunk lines do not usually have taps. For example, the trunk can be run at 10 dBmV even though the forward path level is no longer 47 dBmV. Pad 1 is set to 0 dB if a bridger gate switch (BGS) is used or to 7 dB if a BGS is not used and the levels at the trunk diplex filter are aligned identical to the levels at the bridger diplex filter.

Using Express Feeders

Use of express feeders often requires different forward path levels in various sections of the plant. For example, the express feeder (untapped) sections can be driven at 44 dBmV, while the tapped feeders are driven at 51 dBmV. If the rules stated in *Changes in Forward Levels* on page A-1 were followed, the return path needs to be aligned to different levels in the express feeder versus the tapped feeder sections. However, if the express feeder is not tapped, the return path signals in that section can be run at the same levels as they are in the tapped section of

STATION BLOCK DIAGRAMS

The following illustrations and losses are representative of the amplifiers, line extenders, and optical nodes most commonly used in forward and return path transmission.

Figure B.1

BTN optical node

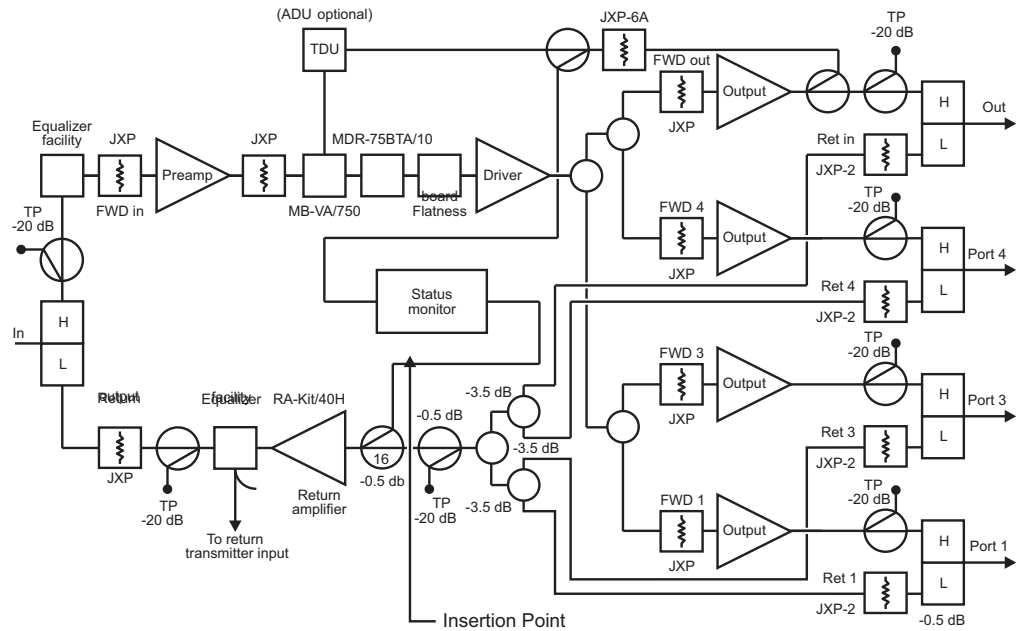

Insertion Point	Test Point Loss	Loss Between Duplex Filter and Test Point	"Insertion Point Loss" (Actual Loss Relative to Duplex Filter)
Status Monitor Connector	16	9	7

Figure B.2

AM-MBR optical node

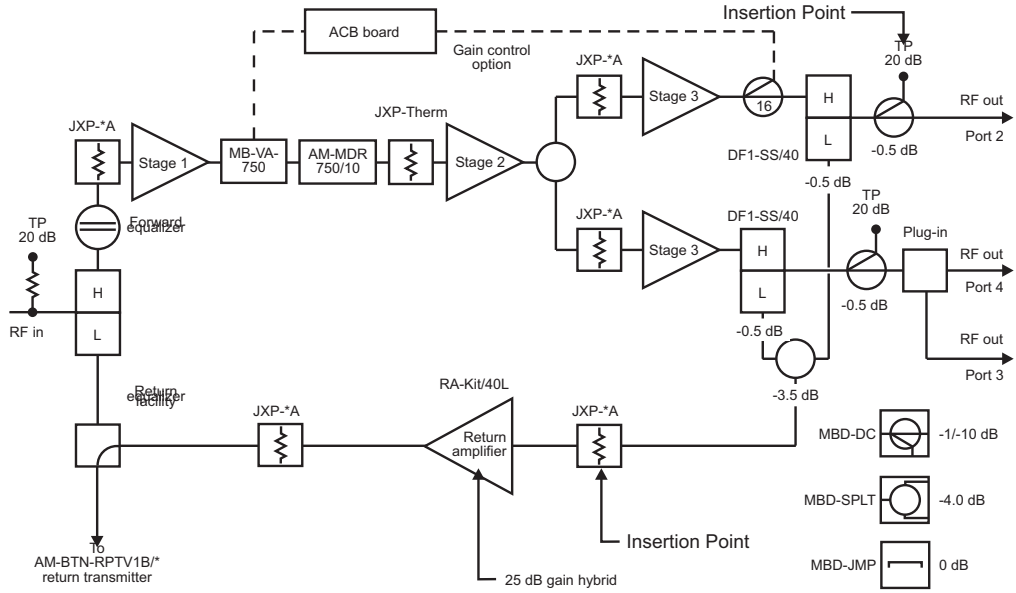

Insertion Point	Test Point Loss	Loss Between Diplex Filter and Test Point	"Insertion Point Loss" (Actual Loss Relative to Diplex Filter)
Output test point	20	0	20
JXP Before Return Hybrid	0	4	-4

Figure B.3

SX optical node

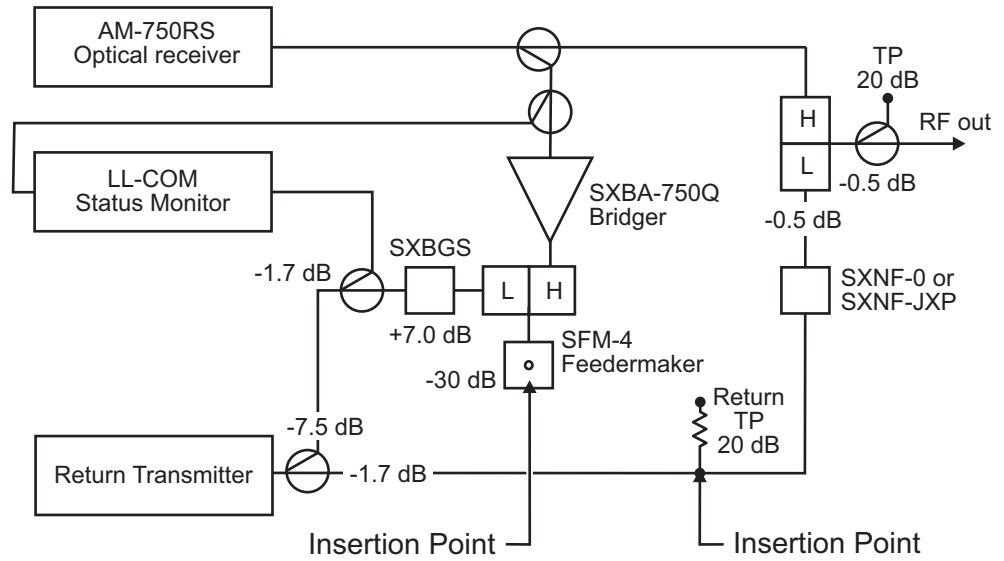

Insertion Point	Test Point Loss	Loss Between Diplex Filter and Test Point	"Insertion Point Loss" (Actual Loss Relative to Diplex Filter)
Return test point	20	1	19
Feeder maker Test Point	30	0	30

Figure B.4

BTD amplifier

B

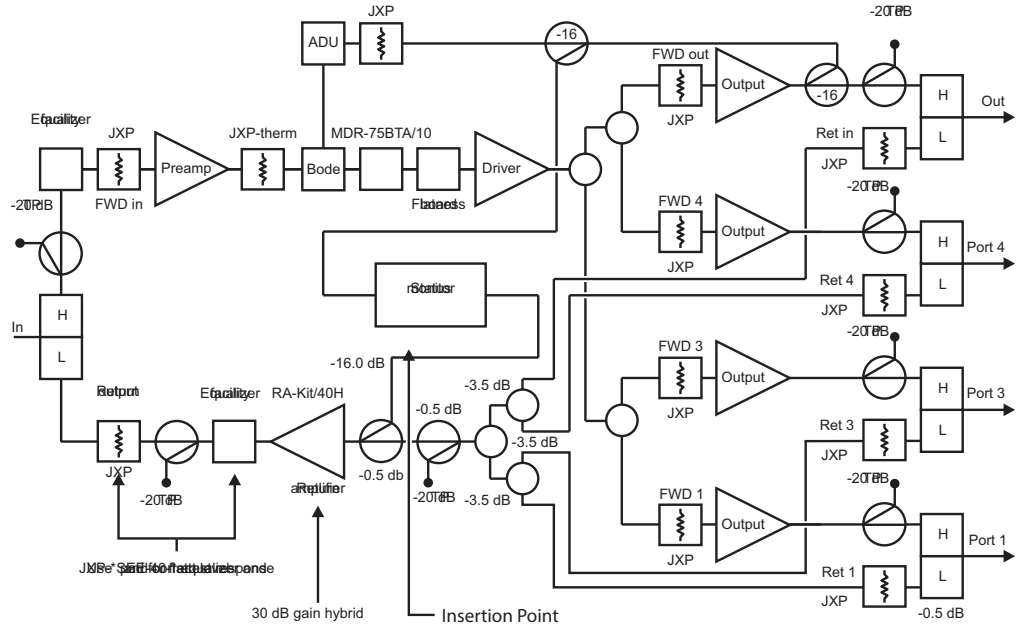

Insertion Point	Test Point Loss	Loss Between Duplex Filter and Test Point	"Insertion Point Loss" (Actual Loss Relative to Duplex Filter)
Status monitor connector	16	9	7

Figure B.5

MB-750D-H/40
amplifier

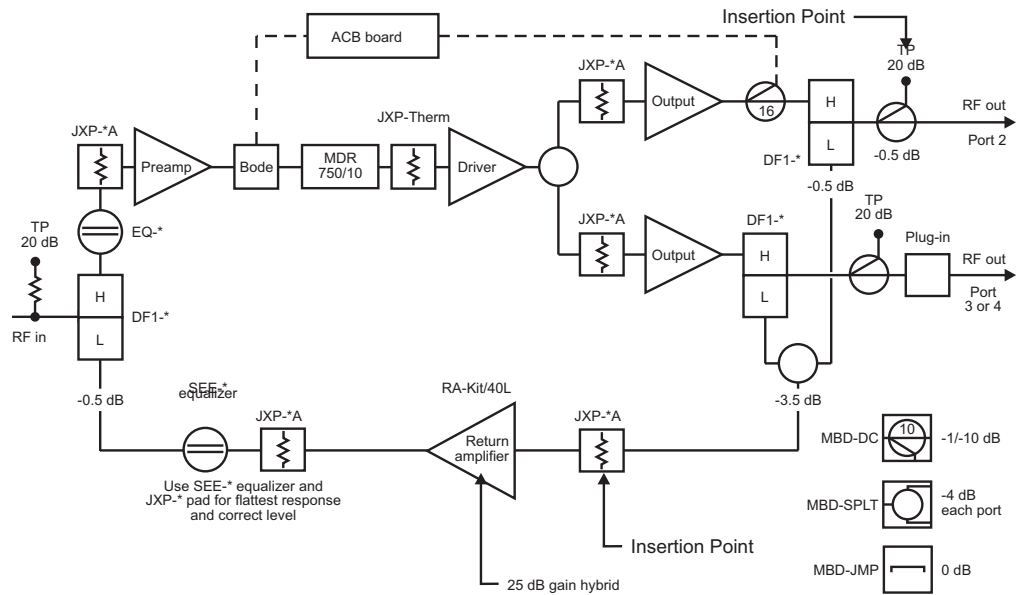

Insertion Point	Test Point Loss	Loss Between Diplex Filter and Test Point	"Insertion Point Loss" (Actual Loss Relative to Diplex Filter)
Output test point	20	0	20
JXP Before Return Hybrid	0	4	-4

Figure B.6

BLE line extender

B

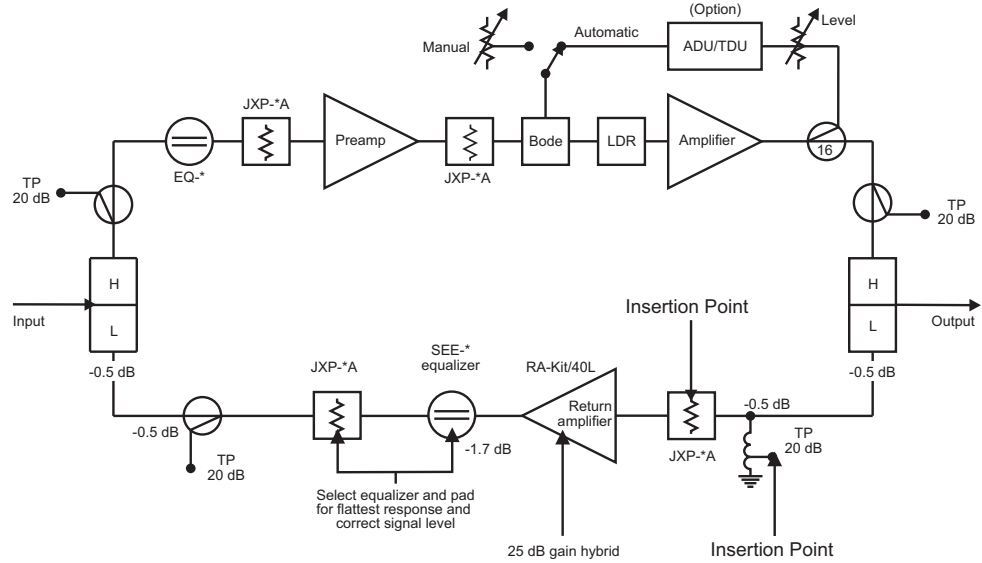

Insertion Point	Test Point Loss	Loss Between Diplex Filter and Test Point	"Insertion Point Loss" (Actual Loss Relative to Diplex Filter)
Test Point Before Return Hybrid	20	0	20
JXP Before Return Hybrid	0	1	-1

Figure B.7

JLX line extender

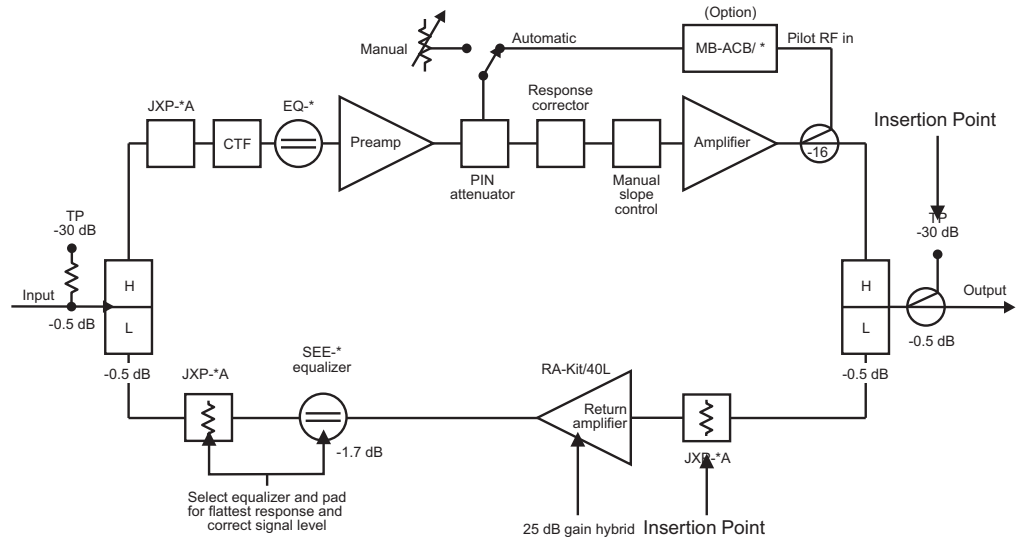

Insertion Point	Test Point Loss	Loss Between Diplex Filter and Test Point	"Insertion Point Loss" (Actual Loss Relative to Diplex Filter)
Output test point	30	0	30
JXP Before Return Hybrid	0	1	-1

Figure B.8

MB-86SH/G mini
bridger

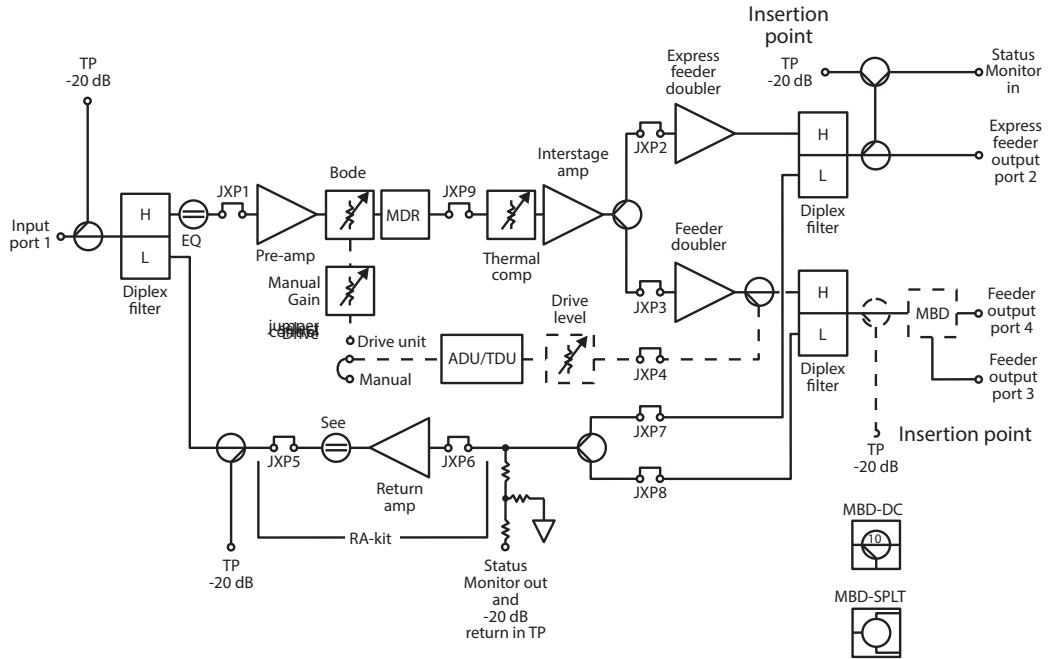

Insertion Point	Test Point Loss	Loss Between Diplex Filter and Test Point	"Insertion Point Loss" (Actual Loss Relative to Diplex Filter)
Output test point	20	0	20

Figure B.9

BLE **/* line extender

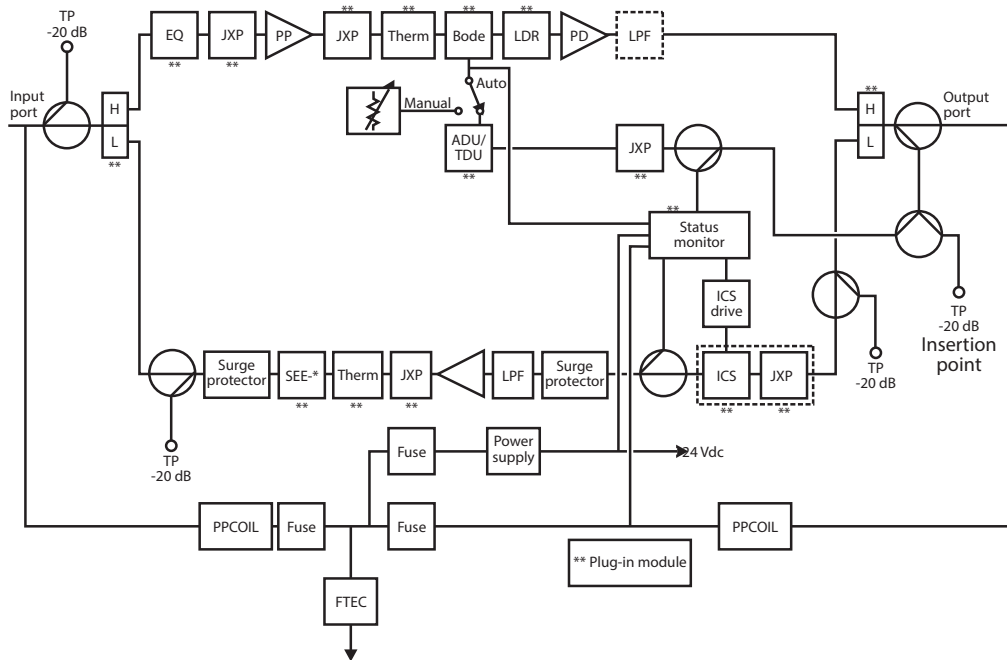

Insertion Point	Test Point Loss	Loss Between Diplex Filter and Test Point	"Insertion Point Loss" (Actual Loss Relative to Diplex Filter)
Output test point	20	0	20

Figure B.10

SG4000 node

Insertion Point	Test Point Loss	Loss Between Diplex Filter and Test Point	"Insertion Point Loss" (Actual Loss Relative to Diplex Filter)
Output test point	20	0	20

DESIGN TABLE

The table below is a blank version of Table 2.6 on page 2-7. It can be photocopied and used at your convenience for setting up the parameters required for proper plant design.

Table C.1 Choosing the proper plant level

Step	Description	Procedure	Service 1	Service 2	Service 3
1	Name of service	Enter the name of the service.			
2	Bandwidth	Enter the bandwidth of the service listed in Step 1. This is usually the same as the channel spacing.			
3	Guaranteed maximum level (dBmV)	Enter the guaranteed maximum output level of the service listed in Step 1.			
4	Plant gain errors (dB)	Enter the anticipated maximum plant gain errors. Refer to <i>Plant Gain Errors</i> on page 2-6.			
5	In-house loss (dB)	Enter the maximum in-house loss for the service listed in Step 1. Refer to <i>Adding up the Losses</i> .			
6	Drop loss (dB)	Enter the maximum drop cable loss. Refer to <i>"Adding up the Losses."</i>			
7	Level at tap port (dBmV)	Determined by subtracting Steps 4, 5, and 6 from Step 3.			
8	Loss of feeder cable and taps (dB)	Enter the maximum loss of the feeder cable and taps. Refer to <i>"Loss of Feeder Cable and Taps."</i>			
		Level/Power at Amplifier Input			
9	Level at amplifier input (dBmV)	Determined by subtracting Step 8 from Step 7.			
10	Power per Hz at amplifier input (dBmV/Hz)	Calculate from the bandwidth in Step 2 and the level in Step 9 by using the "Calculating Power per Hz from Channel Power" conversion formula. Power-per-Hz = channel power -10*log (channel bandwidth).			

11	Total power at amplifier input (dBmV)	This is the total power at the amplifier input port if the service given in Step 1 is used as the basis for choosing the plant operating level. Use the formula "Calculating Total Power from Power per Hz." Total Power = Power per Hz +10*log (total bandwidth).			
----	---------------------------------------	--	--	--	--

GLOSSARY

This chapter provides definitions of the terms and full spelling of the acronyms used in this manual.

AGC

Automatic gain control

Amplifier Module

Refers to the amplifier circuitry inside the amplifier station or node station.

Amplifier Return Path Input

Refers to the station forward path output port. The forward path output and return path input share the same port. This location is usually the same as the unity gain reference point. Unless specifically stated, this term always refers to the station port and not to the amplifier module within the station.

Amplifier Return Input Level

The level at the amplifier return path input.

BGS

Bridger gate switch

BW

Bandwidth

CATV

Cable access television (formerly Community Antenna Television)

CB

Citizens band

C/N

carrier-to-noise

dBm

A measurement relative to 1 milliwatt on a logarithmic scale. In the CATV industry, it is usually used for optical power measurements, but can also be used for RF power measurements. In both cases, 0 dBm refers to 1 mW.

dBmV

A measurement relative to 1 millivolt on a logarithmic scale. Used exclusively for RF measurements as there is no such thing as an “optical voltage.” In a 75-ohm RF system, 0 dBm = 48.75 dBmV.

dBmV/Hz

A measurement of power density in units of dBmV per unit bandwidth.

Insertion Point Loss

The loss from the test point to the unity gain point.

Link Gain

The gain of the optical link measured from the input of the return path transmitter to the output of the optical receiver.

Maximum Link Output Level

The maximum link output level allowed. Selected based on optical receiver distortion performance.

Node

This term can have two definitions based on the context in which it is used:

- Node can refer to the entire section of plant served by a fiberoptic link. For example, one might say “there are 500 homes in this node.”
- Node can refer to the particular amplifier housing in the plant that holds the fiberoptic equipment. In this case, the node is the transition point between optical and RF transmission.

Node Return Full Gain

The internal gain of the node station when all pads are 0 dB.

Node Return Gain

The desired internal gain of the node station. It refers to the difference in levels between the unity gain reference point and the input to the optical transmitter module. The preferred node return gain must be determined before sweeping can begin.

OFDM

Orthogonal frequency division multiplexing

Reference Link Gain

The preferred gain of the optical link. It is usually equal to the gain of the longest optical link.

Reference Link Output Level

The output level of the link when aligned to the reference link gain and fully loaded with signals. It must be less than or equal to the maximum link output level.

RF

Radio Frequency

Terminal Equipment

The equipment located at the subscriber's premises for communication over the cable plant. Can refer to set-top terminals, cable modems, or any other piece of equipment that is designed to send information over the cable plant.

Unity Gain Reference Point

Also called unity gain point. It refers to the point at each amplifier station that should have a gain of 0 dB to every other station in the plant.

Unity Gain Reference Sweep

A sweep of the gain from the unity gain reference point in the node station to the output of the fiberoptic receiver in the headend once the node is properly aligned. If tones are used instead of a sweep, then it refers to the gain of each tone.

Return Path Level Selection, Setup, and Alignment Procedure Reference Guide

Corporate Headquarters
ARRIS · Suwanee · Georgia · 30024 · USA
T: 1-678-473-2000 F: 1-678-473-8470
www.arris.com

